

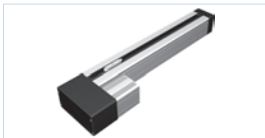











Linear units

Overview

LES functional overview		C 58
LES 4 with spindle drive		C 60
LES 6 with spindle drive		C 62
LES 5 with spindle drive		C 64
LES 16-150 with spindle drive		C 66
LES 16-250 with spindle drive		C 67
Calculations		C 68
Combination examples		C 70
Motor modules		C 72
Installation kit <small>with angular transmission</small>		C 76
Slot/crossbench plates		C 78
T-key slot plates		C 81
Angle bracket		C 82
Accessories		C 85
Cross bench 10/20		C 86

Linear units

Overview

LEZ functional overview		C 88
LEZ 1 with toothed belt drive		C 90
LEZ 2 with toothed belt drive		C 92
LEZ 3 with toothed belt drive		C 94
LEZ 9 with toothed belt drive		C 96
Accessories		C 98
Examples in use		C 99
iLD with direct drive	 	C 100

CAD data on our website www.isel-germany.de

Functional overview

at example LES 5

Plastic cap
electromagnetically shielded

Clamping surface
milled flat

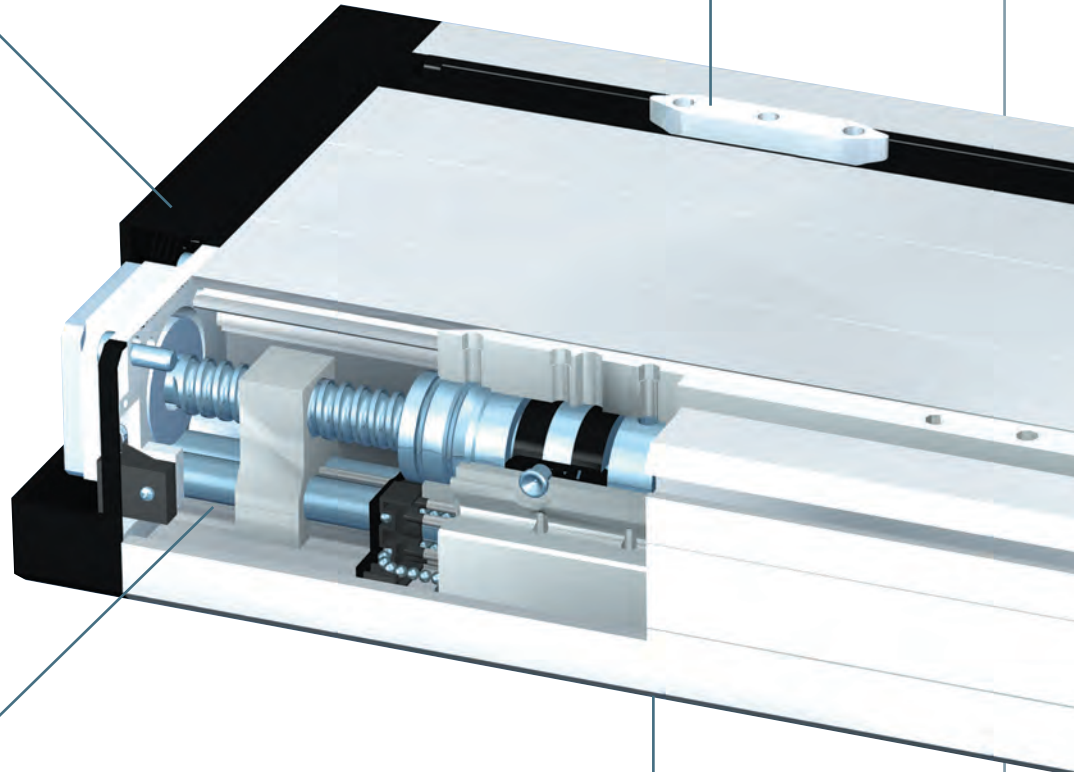

Shaft housing outline
precision milled

Profile underside
milled flat

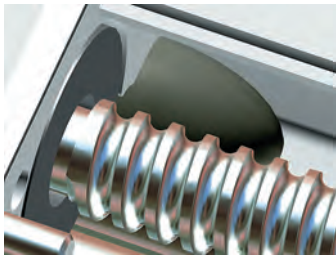

- End position buffering both sides with soft PVC parabolic springs
- Counter-bearing with 2 needle bushings

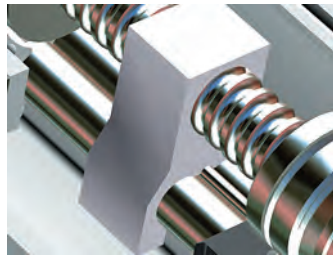

- Spindle support from a profile length of 1500 mm without limiting the travel

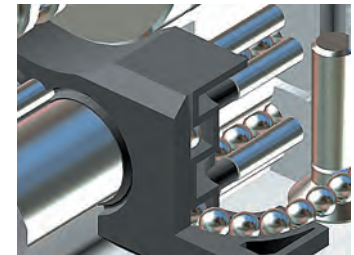

- Recirculating ball in patented aluminium linear slots
- Glass fibre reinforced loop components with scrapers

Functional overview

at example LES 5

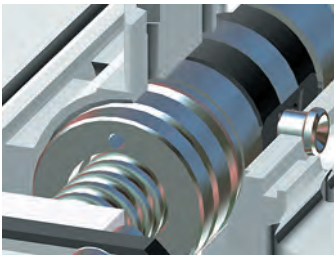
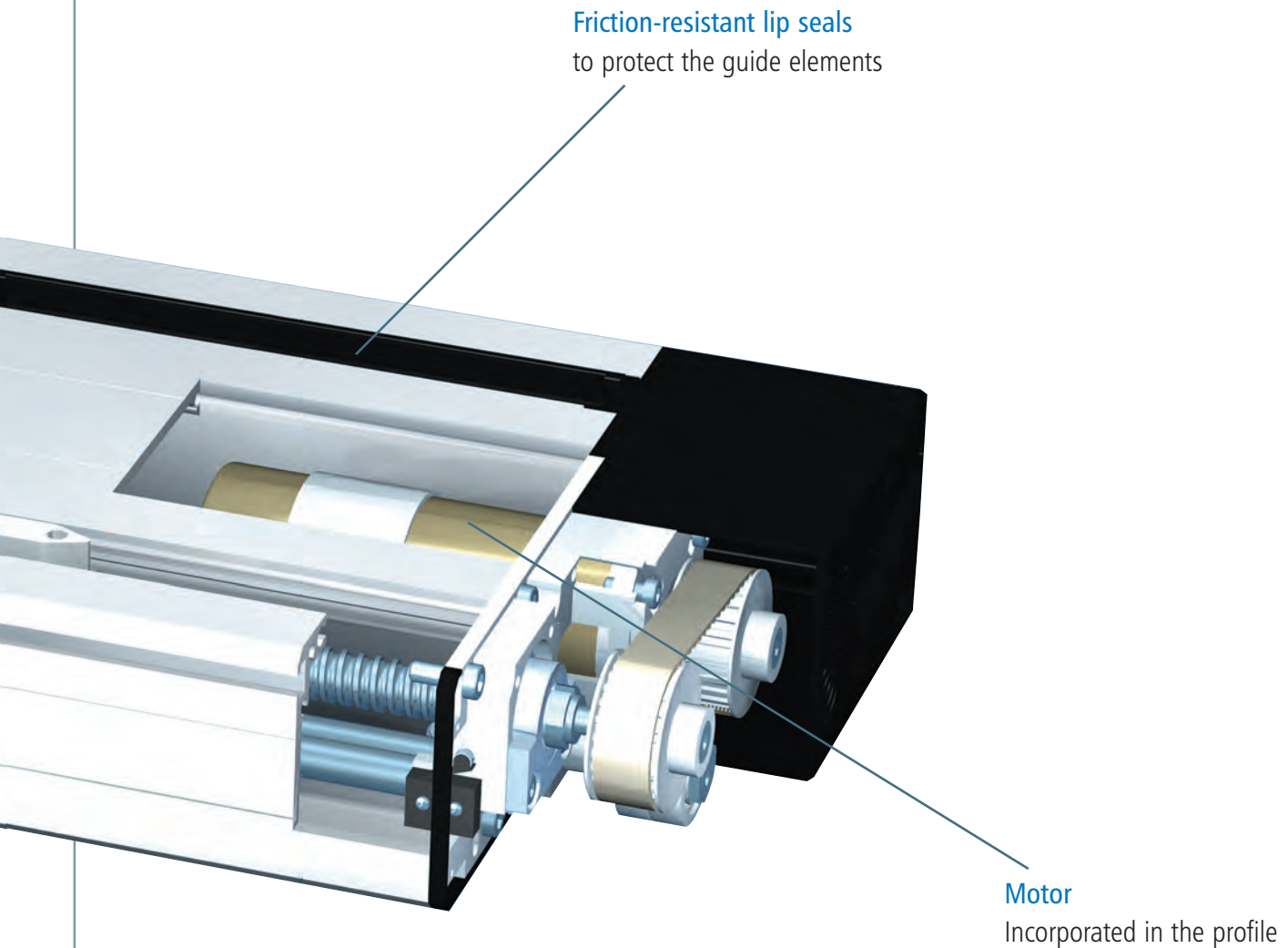

- Preset play-free recirculating ball nut with scrapers
- Central lubrication system for recirculating ball nut and circulations

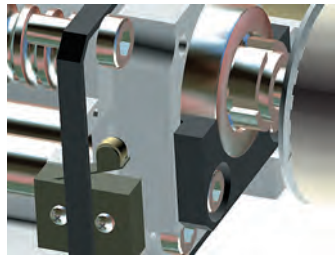

- Integrated overrun limit switch
- Spindle bearing with angular contact bearings
- Axially free from play by means of self-locking special nuts

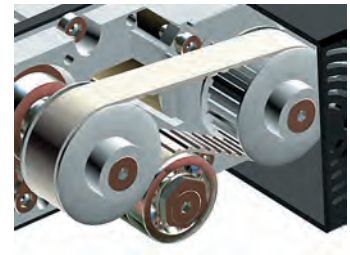

- Belt return and connecting electronics covered completely by protective cap

Linear units with spindle drive

LES 4

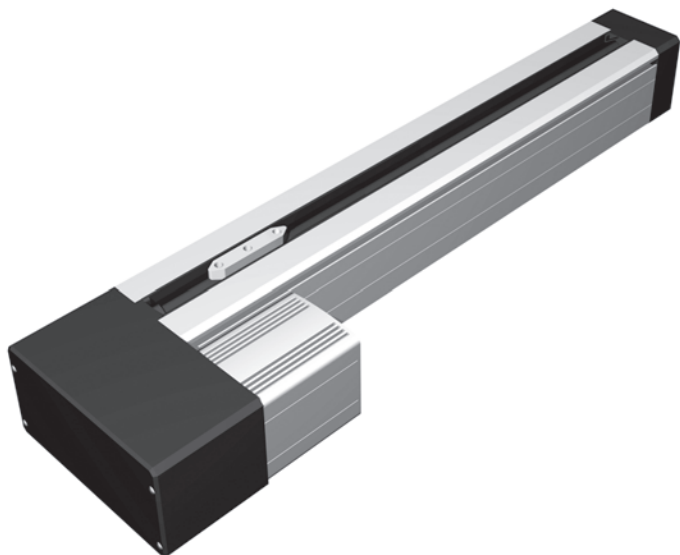

LES 4 with side belt drive module

Features

- Aluminium shaft housing profile W75 × H75 mm, naturally anodised
- Clamping area and profile underside milled flat
- with 2 precision steel shafts Ø 12 h6, material Cf53, Hardness 60 ± 2 HRC
- Aluminium shaft slots WS 5/70, 2 x WS 5/70 (70 mm long), adjustable for no play, central lubrication system
- Recirculating ball transmission with 2.5/4/5/10 and 20 mm pitches
- Profile sealing with friction-resistant lip seals
- Cast aluminium end plates
- with 2 limit or reference switches, Repeatability ± 0.02 mm
- sealed angular contact bearings in drive - steel flange

Ordering key

234 XXX 0XXX

Drive

- 0 = Preparation Direct drive modules
- 1 = Preparation Belt drive module

Shaft slots

- 0 = 1 Shaft slots 70 mm
- 2 = 2 shaft slots 70 mm

Profile length (L1)

e.g. 029 = 290 mm (min.)
299 = 2990 mm (max.)
(rounded to the last digit)

Standard profile lengths in 100 mm raster - to order

Recirculating ball drive

- 0 = none
- 1 = Pitch 2.5 mm
- 2 = Pitch 4.0 mm
- 3 = Pitch 5.0 mm
- 4 = Pitch 10 mm
- 5 = Pitch 20 mm

Options:

- Black powder-coated aluminium profile
- Electromagnetic brake
- Steel slots LS2 (Part no. 223007)
- Limit switch attachment kit (see accessories)

Drive modules

see page 72 et seq. of the catalogue

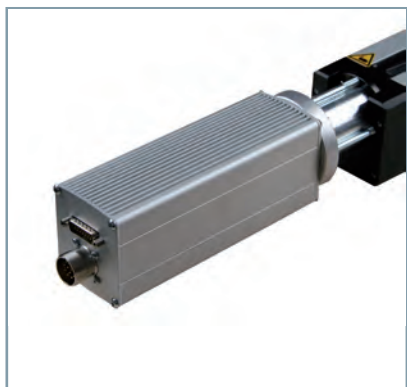

Technical specification

Aluminium profile

Aluminium profile LES 4	
Moment of inertia I _x	107.711 cm ⁴
Moment of inertia I _y	125.843 cm ⁴
*Centre of gravity <small>see dimensioned drawing</small>	33.23 mm
Cross-sectional area	18.81 cm ²
Material	AlMgSiO, 5F22
Anodising	E6/EV1
Weight with steel shafts	6.2 kg/m
Weight with steel shafts and spindles	7.6 kg/m

No load running torques

No load running torques					
Speed (rpm)	Spindle pitch				
	2.5	4	5	10	20
500	15	15	16	17	18
1500	19	19	19	20	21
3000	23	24	24	25	26

Linear units with spindle drive

LES 4

Bending

■ Load config. 1

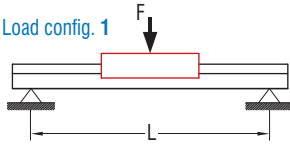

■ Load config. 2

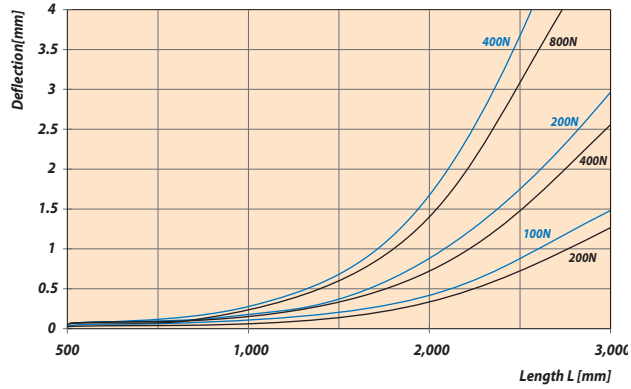
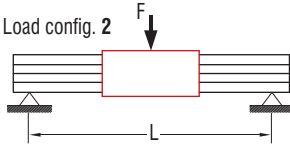

Load factors

$$Fr(\alpha) = \frac{F_2}{\cos \alpha}$$

$$Fr(\alpha) = \frac{F_1}{\sin \alpha}$$

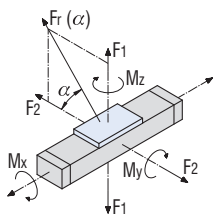

LES 4 with one WS 5/70

C₀	2576.65 N
C	1461,14 N
F_{1 stat.}	2200.67 N
F_{1 dyn.}	1247.93 N
F_{2 stat.}	2576.65 N
F_{2 dyn.}	1461.14 N
M_{x stat.}	36.45 Nm
M_{y stat.}	82.16 Nm
M_{z stat.}	96.20 Nm
M_{x dyn.}	20.67 Nm
M_{y dyn.}	46.59 Nm
M_{z dyn.}	54.55 Nm

LES 4 with two WS 5/70

C₀	4,954.5 N
C	2,809.5 N
F_{1 stat.}	4,231.5 N
F_{1 dyn.}	2,398.5 N
F_{2 stat.}	4,954.5 N
F_{2 dyn.}	2,809.5 N
M_{x stat.}	44.7 Nm
M_{y stat.}	126.945 Nm
M_{z stat.}	148.635 Nm
M_{x dyn.}	25.2 Nm
M_{y dyn.}	71.955 Nm
M_{z dyn.}	84.285 Nm

permissible spindle speeds

LES 4 / 5 / 6	Spindle pitch p [mm]	max. permissible feed speed v permissible [mm/s]				
		2.5	4	5	10	20
Profile length L [mm]	max. permissible spindle speed n [rpm]					
490	4000	167	267	333	667	1333
990	3000	125	200	250	500	1000
1390	1500	63	100	125	250	500
1490 *	3000	125	200	250	500	1000
1990 *	1650	69	110	138	275	550
2490 *	1050	44	70	88	175	350
2990 *	750	31	50	63	125	250

* with spindle support

Dimensioned drawing

process travel

at 1xWS 5/70 = L1 -150 mm
at 2xWS 5/70 = L1 -280 mm

external limit switches see page C85

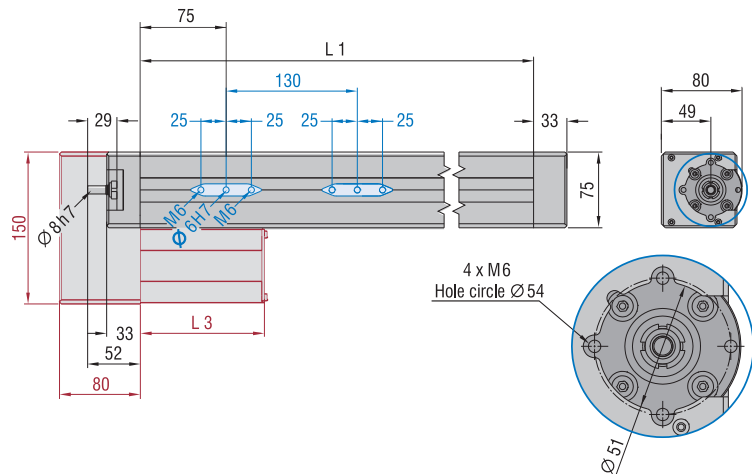

Dimensioned drawing

Aluminium profile

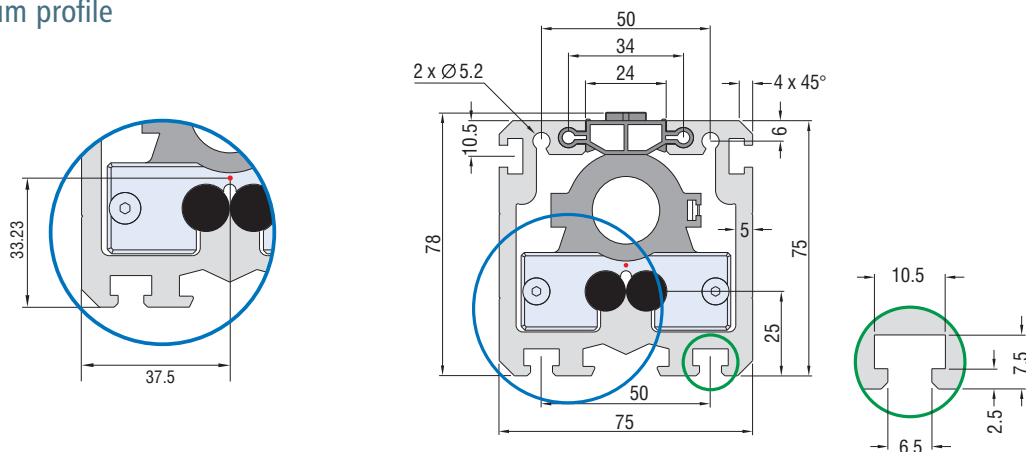

Linear units with spindle drive

LES 6



LES 6 with side belt drive module

Features

- Aluminium shaft housing profile W150 × H75 mm, naturally anodised
- Clamping area and profile underside milled flat
- with 4 precision steel shafts Ø 12 h6, material Cf53, Hardness 60 ± 2 HRC
- Aluminium shaft slots WS 5/70, 2 x WS 5/70 (70 mm long), adjustable for no play, central lubrication system
- Recirculating ball transmission with 2.5/4/5/10 and 20 mm pitches
- Profile sealing with friction-resistant lip seals
- Cast aluminium end plates
- with 2 limit or reference switches, Repeatability ± 0.02 mm
- sealed angular contact bearings in drive - steel flange

Ordering key

234 **XXX** **0XXX**

Drive

- 6** = Preparation Direct drive modules
- 7** = Preparation Belt drive module

Shaft slots

- 0** = 2 shaft slots 70 mm
- 2** = 4 shaft slots 70 mm

Profil length (L1)

e.g. **029** = 290 mm (min.)
299 = 2990 mm (max.)
(rounded to the last digit)

Standard profile length in 100 mm raster – to order

Recirculating ball drive

- 0** = none
- 1** = Pitch 2.5 mm
- 2** = Pitch 4.0 mm
- 3** = Pitch 5.0 mm
- 4** = Pitch 10 mm
- 5** = Pitch 20 mm

Options:

- Black powder-coated aluminium profile
- Electromagnetic brake
- Steel slots LS2 (Part no. 223007)
- Limit switch attachment kit (see accessories)

Drive modules

see page 72 et seq. of the catalogue

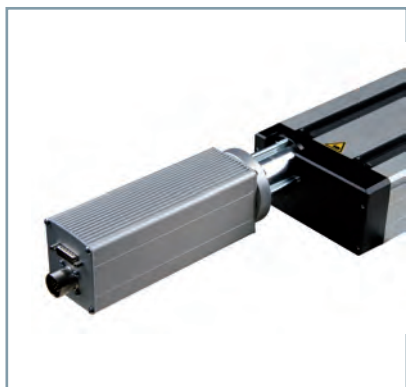

Technical specification

Aluminium profile

Aluminium profile LES 6	
Moment of inertia I _x	707.100 cm ⁴
Moment of inertia I _y	212.200 cm ⁴
*Centre of gravity <small>see dimensioned drawing</small>	32.78 mm
Cross-sectional area	30.07 cm ²
Material	AlMgSiO, 5F22
Anodising	E6/EV1
Weight with steel shafts	11.4 kg/m
Weight with steel shafts and spindles	12.8 kg/m

No load running torques

No load running torques (Ncm)					
Speed (rpm)	Spindle pitch				
	2.5	4	5	10	20
500	17	17	18	20	21
1500	20	20	22	24	25
3000	24	25	26	29	30

Linear units with spindle drive

LES 6

Bending

■ Load config. 1

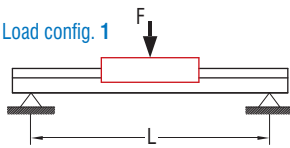

■ Load config. 2

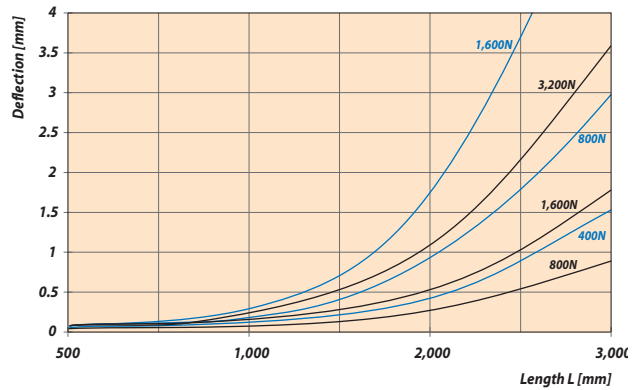
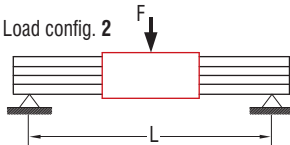

Load factors

$$Fr(\alpha) = \frac{F_2}{\cos \alpha}$$

$$Fr(\alpha) = \frac{F_1}{\sin \alpha}$$

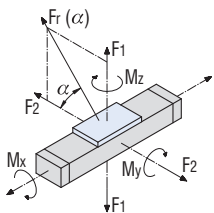

LES 6 with two WS 5/70	
C_0	5153.30 N
C	2319.41 N
F_1 stat.	4401.33 N
F_1 dyn.	1980.96 N
F_2 stat.	5153.30 N
F_2 dyn.	2319.14 N
M_x stat.	211.54 Nm
M_y stat.	164.31 Nm
M_z stat.	192.39 Nm
M_x dyn.	95.21 Nm
M_y dyn.	73.95 Nm
M_z dyn.	86.59 Nm

LES 6 with four WS 5/70	
C_0	6,606 N
C	3,746 N
F_1 stat.	5,642 N
F_1 dyn.	3,198 N
F_2 stat.	6,606 N
F_2 dyn.	3,746 N
M_x stat.	211.575 Nm
M_y stat.	366.73 Nm
M_z stat.	429.39 Nm
M_x dyn.	119.925 Nm
M_y dyn.	207.87 Nm
M_z dyn.	243.49 Nm

permissible spindle speeds

LES 4 / 5 / 6	Spindle pitch [mm]	2.5	4	5	10	20
		max. permissible feed speed [rpm]		max. permissible feed speed v [mm/s]		
490	4000	167	267	333	667	1333
990	3000	125	200	250	500	1000
1390	1500	63	100	125	250	500
1490 *	3000	125	200	250	500	1000
1990 *	1650	69	110	138	275	550
2490 *	1050	44	70	88	175	350
2990 *	750	31	50	63	125	250

* with spindle support

Dimensioned drawing

process travel

at 2 × WS 5/70 = L1 -150 mm
at 4 × WS 5/70 = L1 -280 mm

external limit switches see page C85

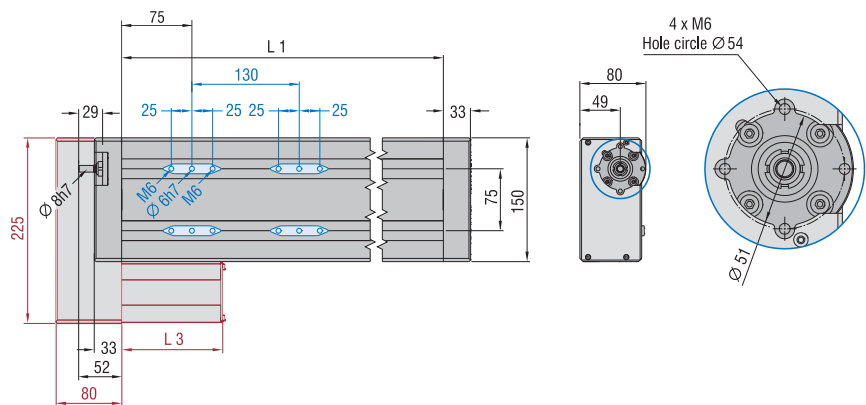

Dimensioned drawing

Aluminium profile

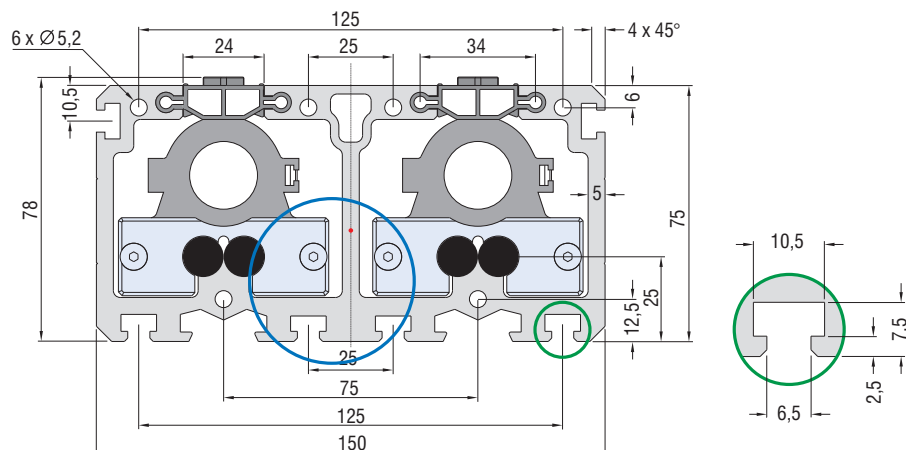
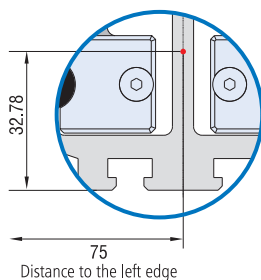

Linear units with spindle drive

LES 5



LES 5 with integrated belt drive module

Features

- Aluminium shaft housing profile W225 × H75 mm, naturally anodised
- Clamping area and profile underside milled flat
- with 4 precision steel shafts Ø 12 h6, material Cf53, Hardness 60 ± 2 HRC
- Aluminium shaft slots WS 5/70, 2 x WS 5/70 (70 mm long), adjustable for no play, central lubrication system
- Recirculating ball transmission with 2.5/4/5/10 and 20 mm pitches
- Profile sealing with friction-resistant lip seals
- Cast aluminium end plates
- with 2 limit or reference switches, Repeatability ± 0.02 mm
- sealed angular contact bearings in drive - steel flange

Ordering key

234 XXX 0XXX

Drive

- 3 = Preparation Direct drive modules
- 4 = Preparation Belt drive module

Shaft slots

- 0 = 2 shaft slots 70 mm
- 2 = 4 shaft slots 70 mm

Profile length (L1)

e.g. 029 = 290 mm (min.)
299 = 2990 mm (max.)
(rounded to the last digit)

Standard profile lengths in 100 mm raster - to order

Recirculating ball drive

- 0 = none
- 1 = Pitch 2.5 mm
- 2 = Pitch 4.0 mm
- 3 = Pitch 5.0 mm
- 4 = Pitch 10 mm
- 5 = Pitch 20 mm

Options:

- Black powder-coated aluminium profile
- Electromagnetic brake
- Steel slots LS2 (Part no. 223007)
- Limit switch attachment kit (see accessories)

Drive modules

See page 72 et seq. of the catalogue

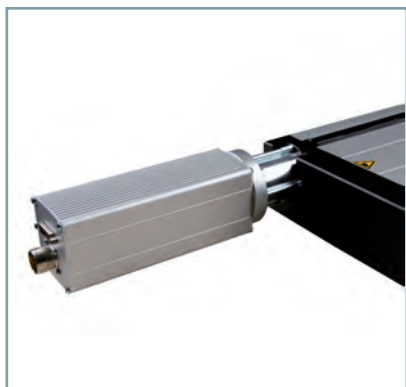

Technical specification Aluminium profile

Aluminium profile LES 5	
Moment of inertia I _x	2,361.654 cm ⁴
Moment of inertia I _y	298.925 cm ⁴
*Centre of gravity <small>see dimensioned drawing</small>	33.39 mm
Cross-sectional area	42.49 cm ²
Material	AlMgSi0, 5F22
Anodising	E6/EV1
Weight with steel shafts	13.8 kg/m
Weight with steel shafts and spindles	15.2 kg/m

No load running torques

No load running torques (Ncm)					
Speed (rpm)	Spindle pitch				
	2.5	4	5	10	20
500	15	15	16	17	18
1500	19	19	19	20	21
3000	23	24	24	25	26

Linear units with spindle drive

LES 5

Bending

■ Load config. 1

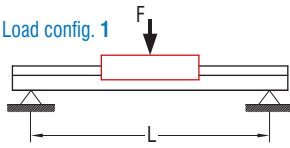

■ Load config. 2

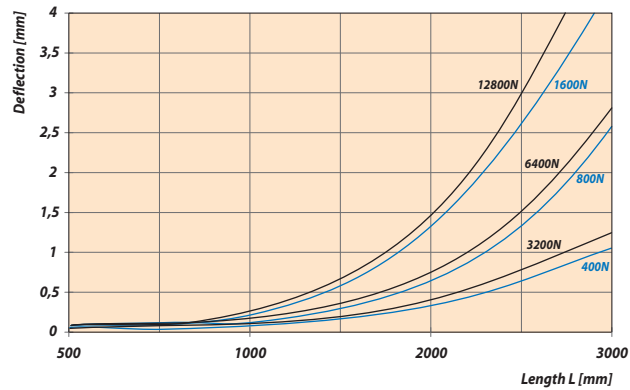
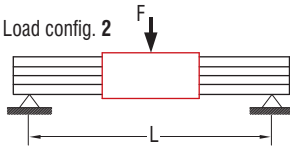

Load factors

$$Fr(\alpha) = \frac{F_2}{\cos \alpha}$$

$$Fr(\alpha) = \frac{F_1}{\sin \alpha}$$

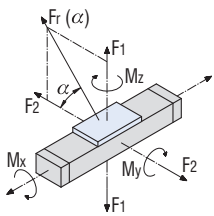

LES 5 with two WS 5/70	
C ₀	5153.30 N
C	2319.41 N
F _{1 stat.}	4401.33 N
F _{1 dyn.}	1980.96 N
F _{2 stat.}	5153.30 N
F _{2 dyn.}	2319.14 N
M _{x stat.}	376.59 Nm
M _{y stat.}	164.31 Nm
M _{z stat.}	192.39 Nm
M _{x dyn.}	169.49 Nm
M _{y dyn.}	73.95 Nm
M _{z dyn.}	86.59 Nm

LES 5 with four WS 5/70	
C ₀	6,606 N
C	3,746 N
F _{1 stat.}	5,642 N
F _{1 dyn.}	3,198 N
F _{2 stat.}	6,606 N
F _{2 dyn.}	3,746 N
M _{x stat.}	423.15 Nm
M _{y stat.}	366.73 Nm
M _{z stat.}	429.39 Nm
M _{x dyn.}	239.85 Nm
M _{y dyn.}	207.87 Nm
M _{z dyn.}	243.49 Nm

permissible spindle speeds

LES 4 / 5 / 6	Spindle pitch p [mm]	max. permissible spindle speed n [rpm]					max. permissible feed speed v permissible [mm/s]				
		2.5	4	5	10	20	2.5	4	5	10	20
490	4000	167	267	333	667	1333					
990	3000	125	200	250	500	1000					
1390	1500	63	100	125	250	500					
1490 *	3000	125	200	250	500	500					
1990 *	1650	69	110	138	275	550					
2490 *	1050	44	70	88	175	350					
2990 *	750	31	50	63	125	250					

* with spindle support

Dimensioned drawing

process travel

at 2xWS 5/70 = L1 -150 mm
at 4xWS 5/70 = L1 -280 mm

external limit switches see page C85

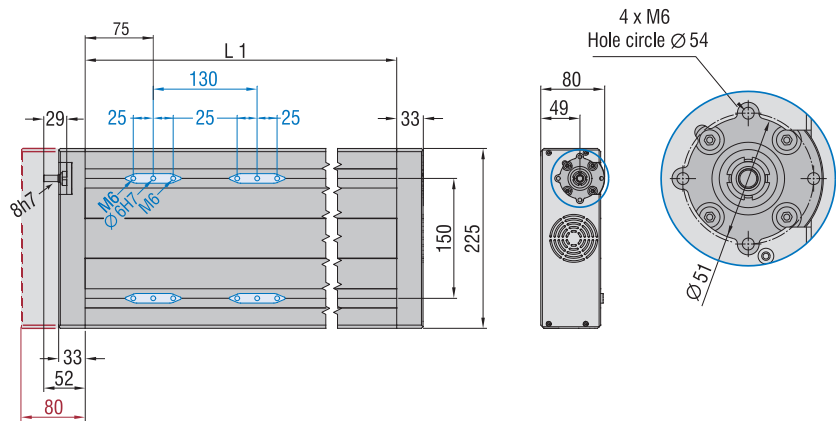

Dimensioned drawing

Aluminium profile

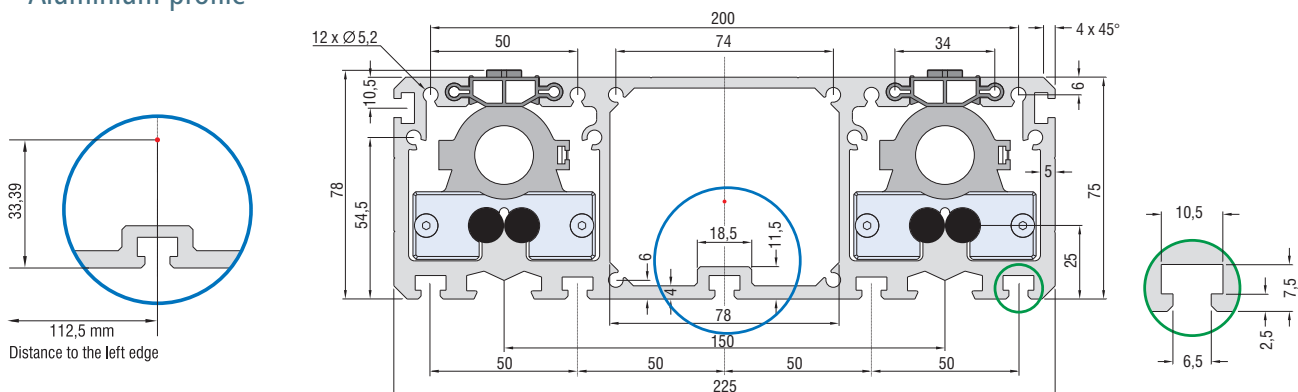

Linear units with spindle drive

LES 16-150

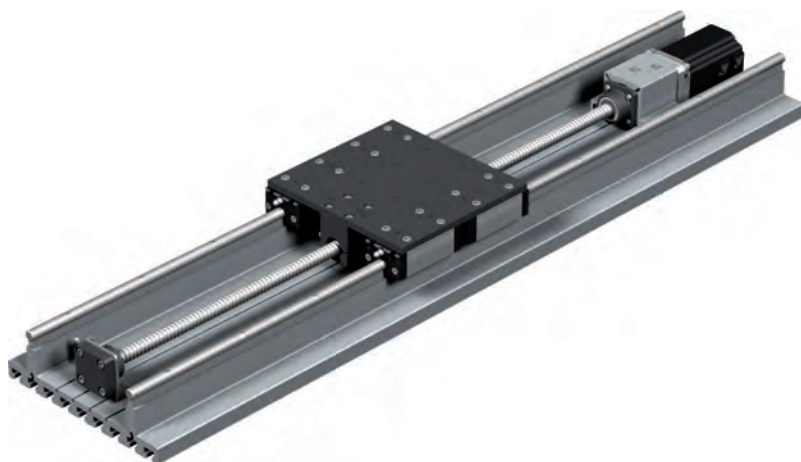

Features

- Aluminium shaft housing profile W 225 × H 65.3 mm
- Length: 0.5/1.0/1.5 m
Intermediate sizes to order
- 2 precision steel shafts Ø 16 mm with exactly milled shaft housings
- 4 aluminium slides IWS 1
- Central lubrication option
- 2 limit or reference switches
- Repeatability ± 0.01 mm
- Recirculating ball drive Ø 16 × 5 mm
- various drive options

Options:

- Other lengths (longer or shorter)
- Profile cover
- Ball screw drive Ø16×2.5mm /10mm

General

Linear units in the LES series with spindle drive are of modular construction and can be used for a wide variety of applications. They are based on rigid aluminium profiles with precision steel shafts. Recirculating ball drives produce the feed movement, multiphase motors or servomotors are used as motor drives. Linear units in the LES series can be used either horizontally or vertically. Patented shaft slots with recirculating balls are used as guide slots. The load-bearing balls also run between 2 ground steel pins and the guide shaft respectively. The desired dimensions can be delivered up to a length of 3 metres according to customer requirements.

Technical specification

Moment of inertia I_x	1899.61 cm ⁴
Moment of inertia I_y	104.94 cm ⁴
Cross-sectional area	39.63 cm ²
Material	AlMgSi0, 5F22
Anodising	E6/EV1
Weight with steel shafts	12.43 kg/m

Ordering data

Part-no.: **238053 004907*** (Length 0,5 m)
 Part-no.: **238053 009907*** (Length 1 m)
 Part-no.: **238053 014907*** (Length 1.5 m)

* including Motor

Dimensioned drawing

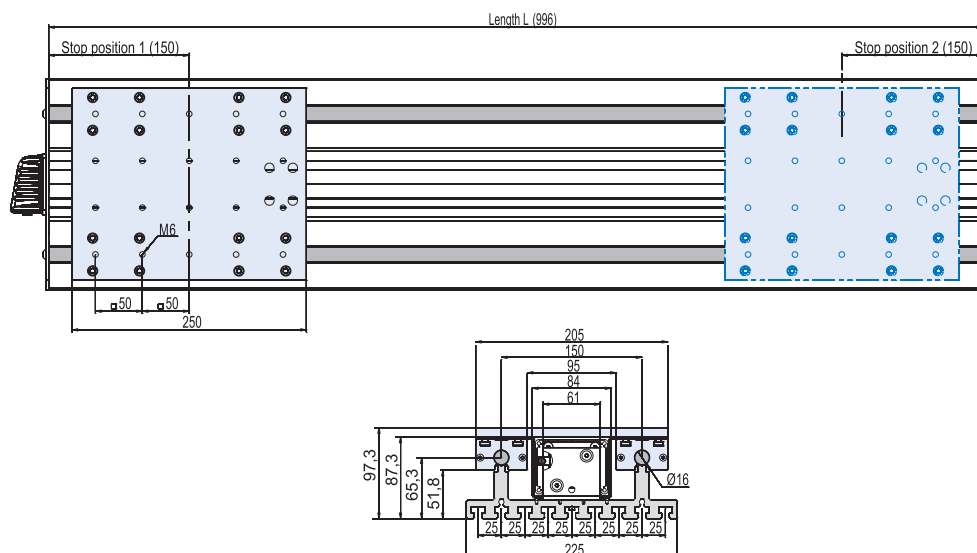

Linear units

with spindle drive

LES 16-250

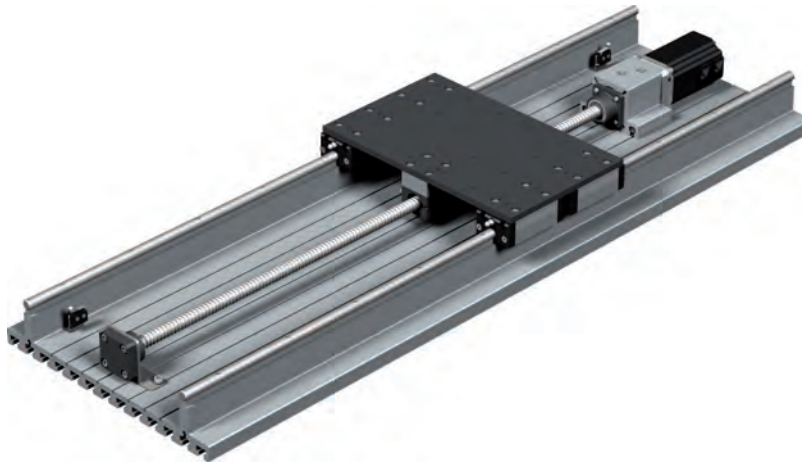

Features

- Aluminium shaft housing profile W 325 × H 65.3 mm
- Length: 0.5/1.0/1.5 m
Intermediate sizes to order
- 2 precision steel shafts Ø 16 mm with exactly milled shaft housings
- 4 aluminium slides IWS 1
- Central lubrication option
- 2 limit or reference switches
- Repeatability ± 0.01 mm
- Recirculating ball drive Ø 16 × 5 mm
- various drive options

Options:

- Other lengths (longer or shorter)
- Profile cover
- Ball screw drive Ø 16 × 2.5 mm/10 mm

General

Linear units in the LES series with spindle drive are of modular construction and can be used for a wide variety of applications. They are based on rigid aluminium profiles with precision steel shafts. Recirculating ball drives produce the feed movement, multi-phase motors or servomotors are used as motor drives. Linear units in the LES series can be used either horizontally or vertically. Patented shaft slots with recirculating balls are used as guide slots. The load-bearing balls also run between 2 ground steel pins and the guide shaft respectively. The desired dimensions can be delivered up to a length of 3 metres according to customer requirements.

Technical specifications

Moment of inertia I_x	5637.55 cm ⁴
Moment of inertia I_y	121,37 cm ⁴
Cross-sectional area	53.63 cm ²
Material	AlMgSi0, 5F22
Anodising	E6/EV 1
Weight with steel shafts	14.41 kg/m

Ordering data

Part no.: **238063 004907*** (Length 0.5m)
 Part no.: **238063 009907*** (Length 1m)
 Part no.: **238063 014907*** (Length 1.5 m)

* including motor

Dimensioned drawing

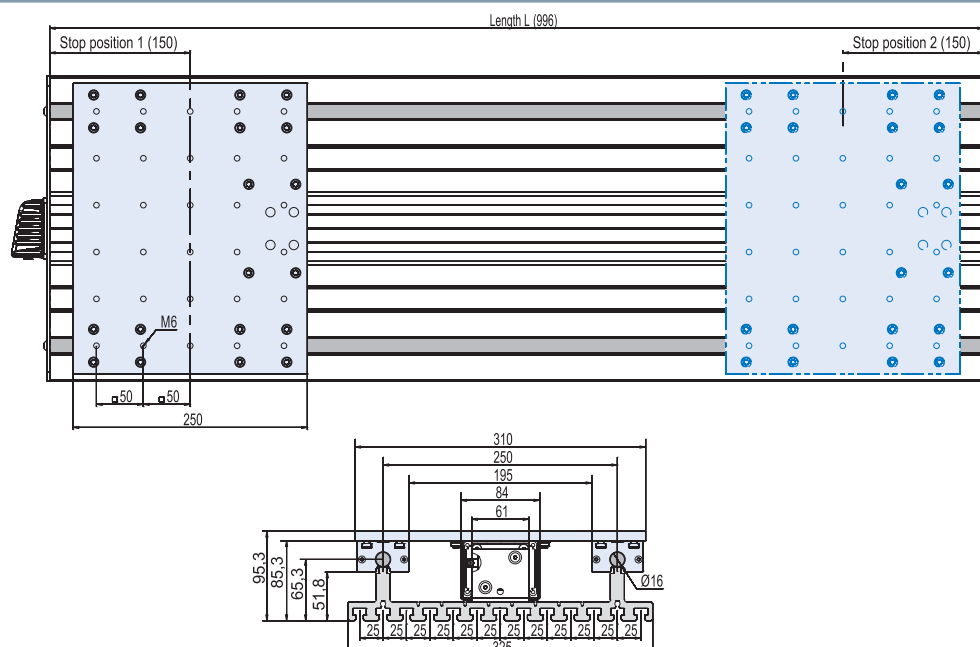

Theoretically critical speed

Calculations

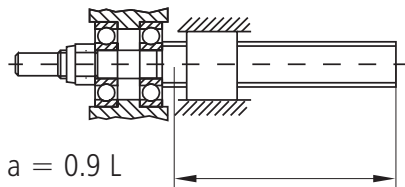
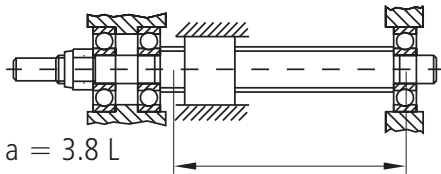

Definitions

$n_{\text{perm.}}$ [min ⁻¹]	maximum permissible speed
a	Installation coefficient
d_2 [mm]	Spindle core diameter
L [mm]	Spindle length between the spindle bearings and spindle ends

Critical speed

In most applications, you need to check tapped spindles at their critical speed.

The critical speed is that speed which causes resonance oscillations of this spindle.

This critical speed depends on the core diameter, the free load-bearing length and on the way the tapped spindle is constructed.

Given a general safety factor of 0.8, the maximum permissible speed can be calculated as follows:

$$n_{\text{perm}} = 392 \cdot \frac{a \cdot d_2}{L^2} 10^5$$

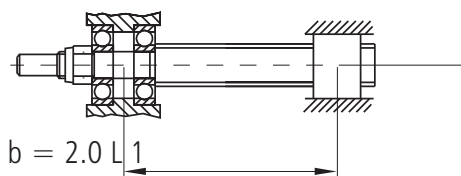
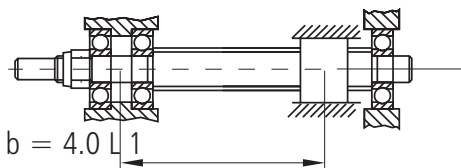

Definitions

F_{perm} [N]	permissible compressive loading
d_2 [mm]	Spindle core diameter
L_1 [mm]	free buckling length, i.e. the maximum distance between the central bearing and the centre of the tapped nut
b	Installation coefficient

Buckling load

The recirculating ball spindle should as far as possible be subjected only to tensile stress. If it is subjected to compressive loads, then the spindle may buckle.

With a safety factor of 3.0 against buckling, the result is

$$F_{\text{zul}} = \frac{34\,000 \cdot b \cdot d_2^4}{L_1^2}$$

Drive dimensioning

Calculations

Drive torque calculation

The required drive torque is made up of

- Load torque M_{load}
- Acceleration torques M_{trans} and M_{rot}
- No load torque $M_{no\ load}$

$$M_A = M_{load} + M_{trans} + M_{rot} + M_{no\ load}$$

Load torque

$$M_{last} = \frac{F_X \cdot p}{2 \cdot \pi \cdot 1000}$$

with feed force $F_X = m \cdot g \cdot \mu$

Translational Acceleration torque

$$M_{trans} = \frac{F_a \cdot p}{2 \cdot \pi \cdot 1000}$$

with feed force $F_a = m \cdot a$

If used vertically, the mass acceleration a must be added to the acceleration due to gravity g ($9.81\ m/s^2$).

Rotational acceleration torque

$$M_{rot} = \frac{J_{sp} \cdot L \cdot n_{max} \cdot a \cdot 2 \cdot \pi}{V_{max} \cdot 60 \cdot 1000}$$

Drive power

$$P = \frac{M_A \cdot n_{max}}{9550}$$

Definitions

M_A	[Nm]	required drive torque
M_{leer}	[Nm]	Torque, resulting from the various loads
M_{leer}	[Nm]	No load torque
M_{rot}	[Nm]	Rotational acceleration torque
M_{trans}	[Nm]	translational acceleration torque
F_X	[N]	Feed force
g	[m/s ²]	Acceleration due to gravity
v_{max}	[m/s]	maximum process speed
m	[kg]	The weight to be conveyed
a	[m/s ²]	Acceleration
p	[mm]	Spindle pitch
P	[kW]	Power
L	[mm]	Length
n_{max}	[rpm]	maximum speed
μ		coefficient of friction
J_{sp}	[kgm ² /m]	Inertial torque of inertia of the spindle per meter
F_a	[N]	Accelerating force

Combination examples

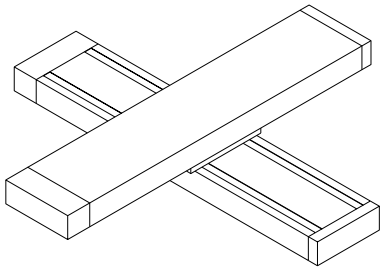

Crossbench
 2 x LES 5
 PS 4 with VP 2

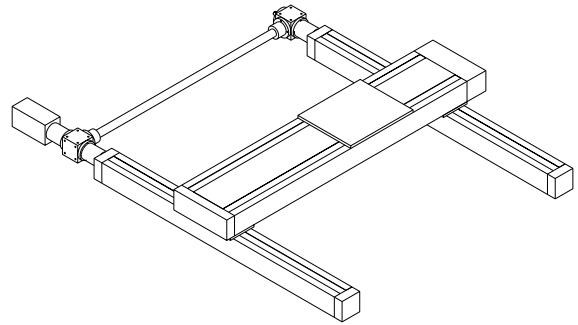

2-axis H-design
 2 x LES 4, LES 5, angular transmission kit,
 2 x PS 6, PS 4

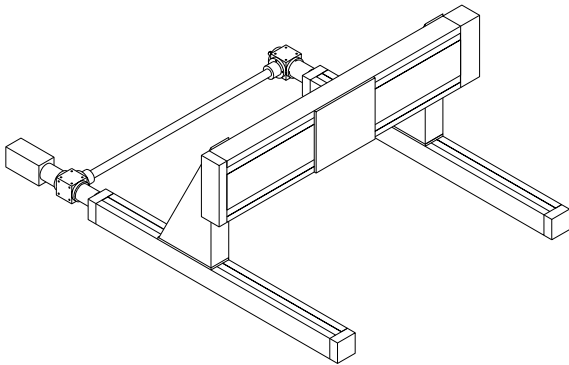

2-axis flatbed configuration
 2 x LES 4, LES 5, angular transmission kit,
 2 x PS 2, 2 x WV 2, PS 4

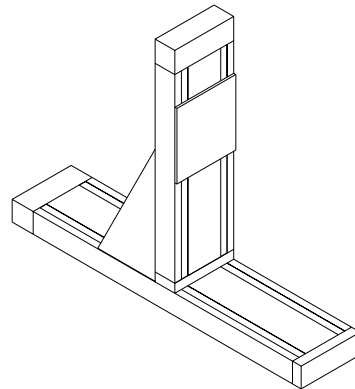

2-axis lifting configuration
 2 x LES 5, 2 x PS 4
 WV 6

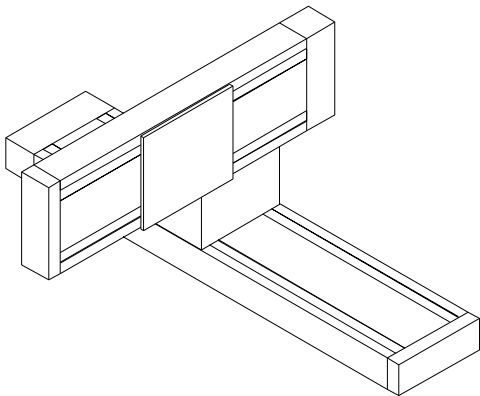

2-axis boom configuration
 2 x LES 5
 2 x PS 4
 WV 3

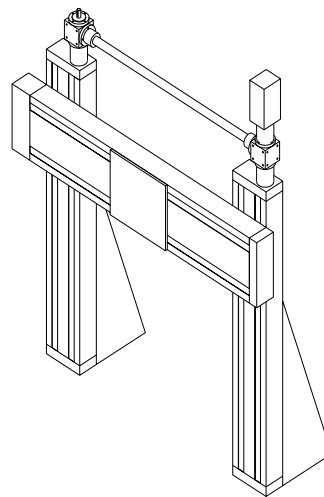

2-axis H-design
 LES 5, 2 x LES 6, 2 x WV 7
 Angular transmission kit, 2 x PS 12
 PS 4

Combination examples

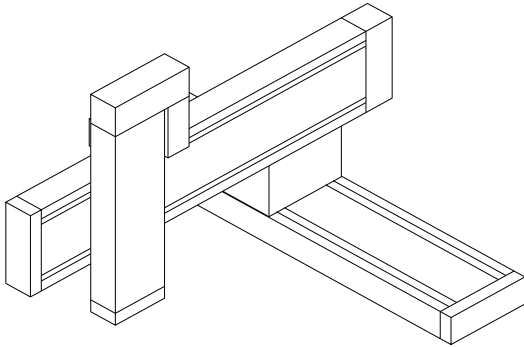

3-axis boom configuration

2 × LES 5, LES 6, WV 3, 2 × PS 4, PS 7

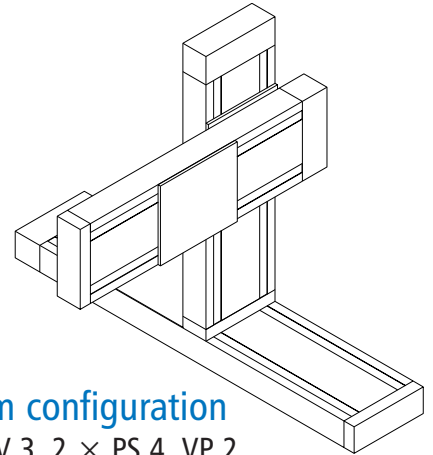

3-axis raised boom configuration

3 × LES 5, WV 3, 2 × PS 4, VP 2

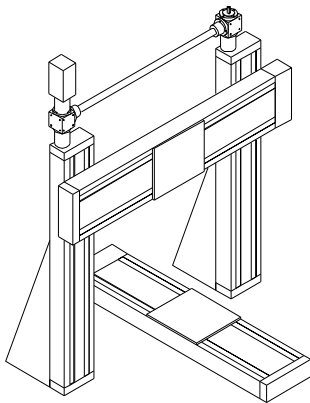

3-axis portal configuration

2 × LES 5, 2 × LES 6, 2 × WV 7
Angular transmission kit, 2 × PS4, PS 12

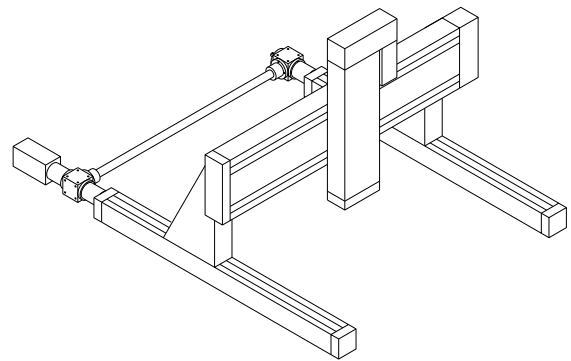

3-axis flatbed configuration

2 × LES 4, LES 5, LES 6, 2 × PS 2, 2 × WV 2
Angular transmission kit, PS 4, PS 7

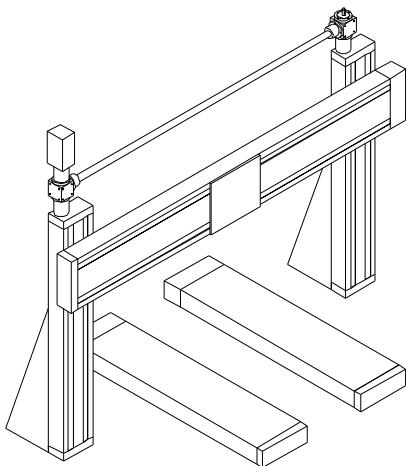

4-axis portal configuration

3 × LES 5, 2 × LES 6, 2 × WV 7
Angular transmission kit
3 × PS 4
2 × PS 12

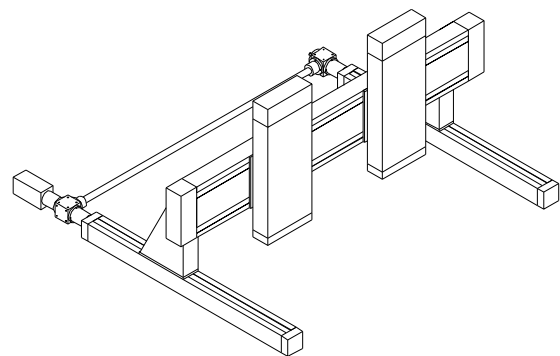

5-axis flatbed configuration

2 × LES 5 (Z-axes)
LES 5 (2 spindle drives)
2 × LES 4, 2 × PS 2, 2 × WV 2
Angular transmission kit, 2 × PS4 with VP 2

Motor modules

Ordering overview

LES 4/5/6 Direct drives	System / circular plug	Z-axis / circular plug with brake
DC servo motor DC 100	396 112 0060	-
Step motor MS 135 HT - 2	396 055 0060	396 055 0360
Step motor MS 200 HT - 2	396 058 0060	396 058 0360
EC servo motor EC 60S	396 415 0060	396 415 0260
EC servo motor EC 60L 48V	396 423 0060	-
EC servo motor EC 60L 310V	396 423 0070	-
DC servo motor DC 300	396 114 0060	-
EC servo motor EC 86L	396 466 0070	-
EC servo motor EC 86S	396 444 0070	-
Step motor MS 600 HT	396 085 0060	-
Step motor MS 900 HT	396 088 0060	-
LES 5 integrated	System / circular plug	Z-axis / circular plug with brake
Step motor MS 135 HT - 2	396 055 1060	396 055 1360
Step motor MS 200 HT - 2	396 058 1060	396 058 1360
DC servo motor DC 100	396 112 1060	-
EC servo motor EC 60S	396 415 1060	396 415 1260
EC servo motor EC 60L 48V	396 423 1060	-
EC servo motor EC 60L 310V	396 423 1070	-
LES 4 / LES 6 side mounting	System / circular plug	Z-axis / circular plug with brake
Step motor MS 135 HT - 2	396 055 2060	396 055 2360
Step motor MS 200 HT - 2	396 058 2060	396 058 2360
DC servo motor DC 100	396 112 2060	-
EC servo motor EC 60S	396 415 2060	396 415 2260
EC servo motor EC 60L 48V	396 423 2060	-
EC servo motor EC 60L 310V	396 423 2070	-

Motor modules

Dimensioned drawing

Motor module 1

Part no.	Motor module	Length L
396112 0060	DC 100	185 mm
396055 0360	MS 135 HT-2 with brake	165 mm
396055 0060	MS 135 HT-2 w/o brake	105 mm
396058 0360	MS 200 HT-2 with brake	165 mm
396058 0060	MS 200 HT-2 w/o brake	105 mm

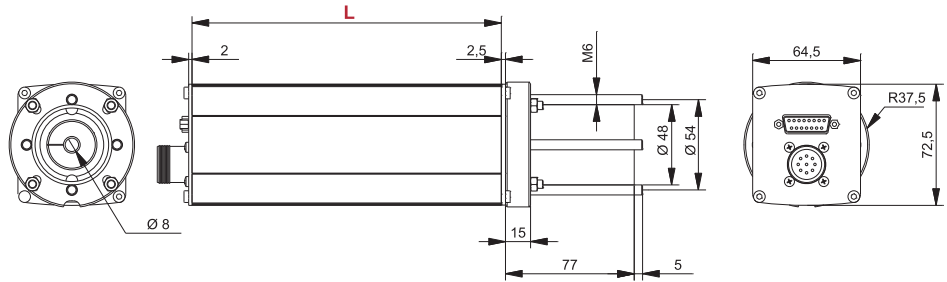

Dimensioned drawing

EC 60

Part no.	Motor module	Length L
396415 0260	EC 60S with brake	99 mm
396415 0060	EC 60S w/o brake	99 mm
396423 0060	EC 60L 48V	120 mm
396423 0070	EC 60L 310V	120 mm

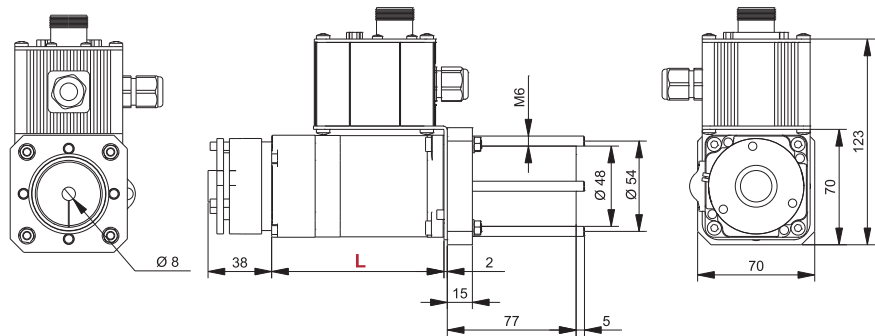

Dimensioned drawing

DC 300

Part no.	Motor module	Length L
396114 0060	DC 300	210 mm

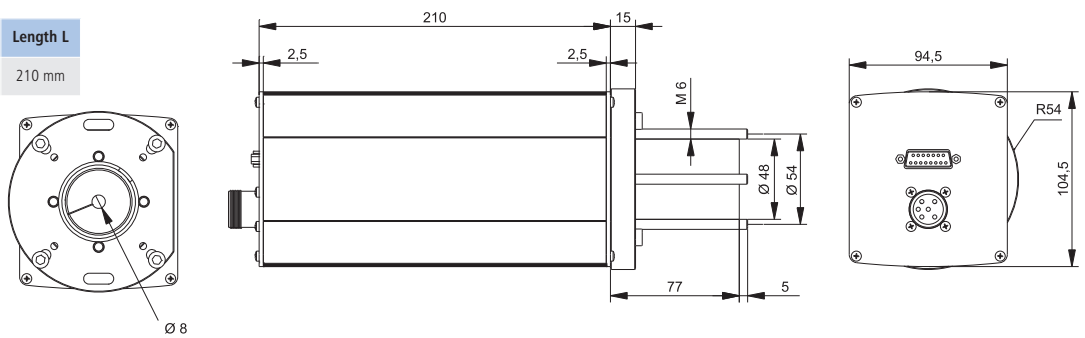

Dimensioned drawing

Motor module 2

Part no.	Motor module	Length L
396466 0070	EC 86L	151 mm
396444 0070	EC 86S	126 mm
396085 0060	MS 600HT	96 mm
396088 0060	MS 900 HT	126 mm

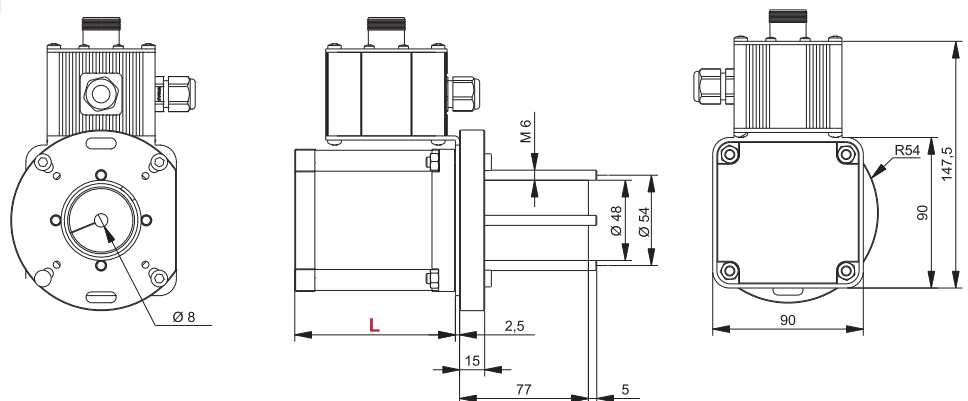

Motor pin assignments

Pin assignment for step motors

Motor connection

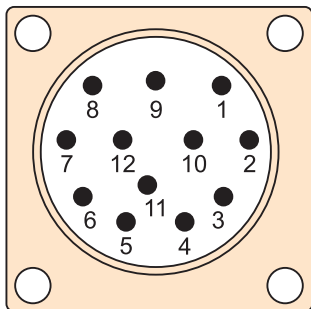

View of pin insert at the insertion side

M23 12-pin Pin	
1	Motor phase 1A
2	Motor phase 1B
3	Motor phase 2A
4	Motor phase 2B
5	+24V switch
6	+24V brake
7	GND switch
8	GND brake
9	Limit switch 1
10	Limit switch 2
11	---
12	---
Housing – cable shield	

Motor connection

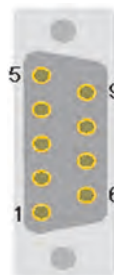

View of pin insert at the insertion side

Sub-D 9-pin Pin	
1	Motor phase 1A
2	Motor phase 1B
3	Motor phase 2A
4	Motor phase 2B
5	+24V switch
6	+24V brake
7	Limit switch 2
8	GND brake
9	Limit switch 1
Housing – cable shield	

Pin assignment for DC servo motors with brushes (BCD)

Motor connection

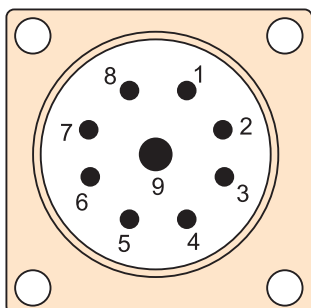

View of pin insert at the insertion side

M23 9-pin (8+1) pin	
1	Motor phase 1 (U+)
2	Motor phase 1 (U-)
3	Motor phase 1 (U+)*
4	Motor phase 1 (U-)*
5	+24V brake
6	GND brake
7	---
8	---
9	Earthing lead
Housing – cable shield	

* Motor phases are connected partially with two wires.

Encoder connection



View of pin insert at the insertion side

Sub-D 15-pin Pin	
1	---
2	+5V encoder
3	Encoder track /Z
4	Encoder track /B
5	Encoder track /A
6	+24V switch
7	Limit switch 1
8	GND switch
9	---
10	GND encoder
11	Encoder track Z
12	Encoder track B
13	Encoder track A
14	Reference switch
15	Limit switch 2
Housing – cable shield	

Pin assignment for brushless EC servo motors (BLDC) 48V

Motor connection

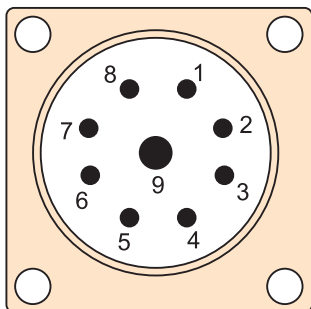

View of pin insert at the insertion side

M23 9-pin (8+1) pin	
1	Motor phase U
2	Motor phase V
3	Motor phase W
4	---
5	+24V brake
6	GND brake
7	---
8	---
9	Earthing lead
Housing – cable shield	

Encoder connection

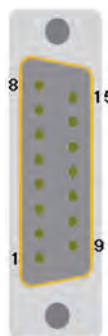

View of pin insert at the insertion side

Sub-D 15-pin Pin	
1	Hall signal A
2	+5V encoder / Hall
3	Encoder track /Z
4	Encoder track /B
5	Encoder track /A
6	+24V switch
7	Limit switch 1
8	GND switch
9	Hall Signal B
10	GND encoder
11	Encoder track Z
12	Encoder track B
13	Encoder track A
14	Hall signal C
15	Limit switch 2
Housing – cable shield	

Motor leads

Pin assignment for brushless EC servo motors (BLDC) 310V

Motor connection

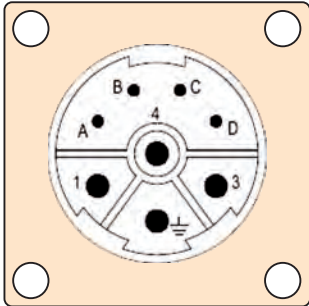

View of pin insert at the insertion side

M23 9-pin (4+3+1) pin	
1	Motor phase U
PE	Earthing lead
3	Motor phase W
4	Motor phase V
A	+24V brake
B	GND brake
C	Temp +
D	Temp -
Housing – cable shield	

Encoder connection



View of pin insert at the insertion side

Sub-D 15-pin Pin	
1	Hall signal A
2	+5V encoder / Hall
3	Encoder track /Z
4	Encoder track /B
5	Encoder track /A
6	+24V switch
7	Limit switch 2
8	GND switch
9	Hall signal B
10	GND encoder
11	Encoder track Z
12	Encoder track B
13	Encoder track A
14	Hall signal C
15	Limit switch 2
Housing – cable shield	

Overview of motor leads for step-, DC servo and EC motors

Part number	Description
392305 0300	3-metre EC/AC servomotor lead M23 310V (4+3+PE) socket - wire end sockets
392305 0500	5-metre EC/AC servomotor lead M23 310V (4+3+PE) socket - wire end sockets
392325 0300	3-metre encoder lead M23 17-pin socket – D-sub 15-pin plug
392325 0500	5-metre encoder lead M23 17-pin socket – D-sub 15-pin plug
392740 0300	3-metre encoder lead D-sub 15-pin plug – socket 1:1
392740 0500	5-metre encoder lead D-sub 15-pin plug – socket 1:1
392750 0300	3-metre step motor lead M23 12-pin plug – socket 1:1
392750 0500	5-metre step motor lead M23 12-pin plug – socket 1:1
392755 0300	3-metre step motor lead D-sub 9-pin plug – M23 12-pin socket
392755 0500	5-metre step motor lead D-sub 9-pin plug – M23 12-pin socket
392759 0300	3-metre DC/EC servomotor lead M23 9-pin (8+PE) plug - socket 1:1
392759 0500	5-metre DC/EC servomotor lead M23 9-pin (8+PE) plug - socket 1:1
392760 0300	3-metre DC/EC servomotor lead M23 9-pin (8+PE) plug – wire end bushings
392760 0500	5-metre DC/EC servomotor lead M23 9-pin (8+PE) plug – wire end bushings
392781 0300	3-metre step motor lead D-sub 9-pin plug – socket 1:1
392781 0500	5-metre step motor lead D-sub 9-pin plug – socket 1:1

All listed motor and encoder leads are fit for use with tow chains.

* Different lengths to order.

Installation kit with angular transmission Drive element accessories

Installation alternatives

Clutch housing kit 90°

Clutch housing kit 0°

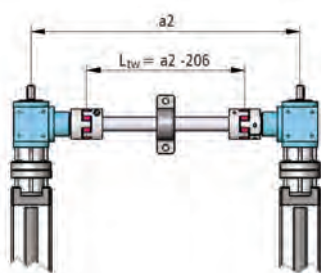
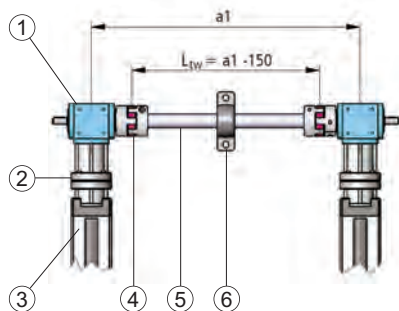

- ① Angular gear
- ② Split coupling casing with shaft coupling WK 40/60
- ③ LES 4, LES 6 or LES 5 (preparation for direct drive)
- ④ Coupling for transmission shaft Ø 25
- ⑤ Transmission shaft Ø 25
- ⑥ Pedestal bearing - recommendable from : transmission shaft length of 1,500 mm up

Dimensioned drawing

Angular transmission

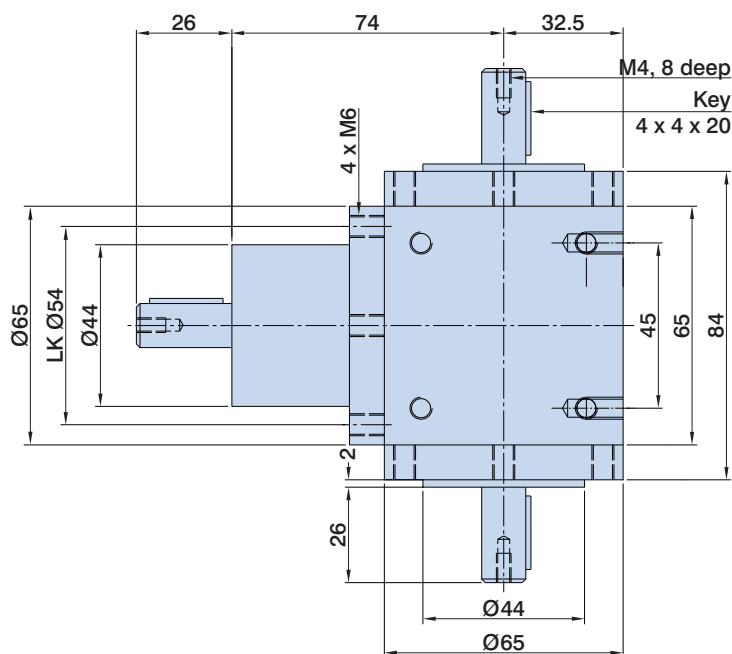
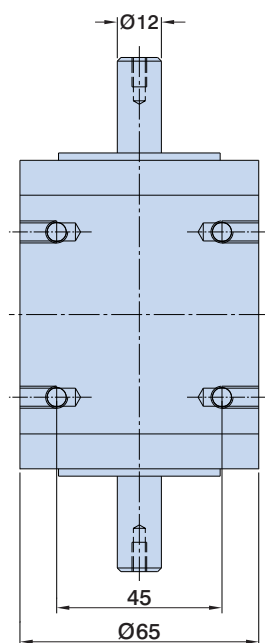

Ordering overview

Installation kit with angular transmission

for H-design on LES 4/LES 6/LES 5, securing 90°

Deliverables: 2 x ①, 2 x ②, 2 x ④

Part no.: **216150 0002**

for H-design on LES 4/LES 6/LES 5, securing 0°

Deliverables: 2 x ①, 2 x ②, 2 x ④

Part no.: **216150 0001**

For matching direct drive modules LES 4/5/6 see table on page "C72".

Transmission shaft

Hollow shaft Ø 25 mm x 4 mm, blank 1000 mm

Part no.: **219001 0125**

Hollow shaft Ø 25 mm x 4 mm, blank 2000 mm

Part no.: **219001 0225**

Coupling / stationary bearing

Coupling for transmission shaft 12 to 25 mm adaptor, VE 2 pcs.

Part no.: **218050 0002**

Stationary bearing for transmission shaft VE 1 pcs.

Part no.: **896202 5562**

Installation kit with angular transmission Drive element accessories

Dimensioned drawing and technical specification

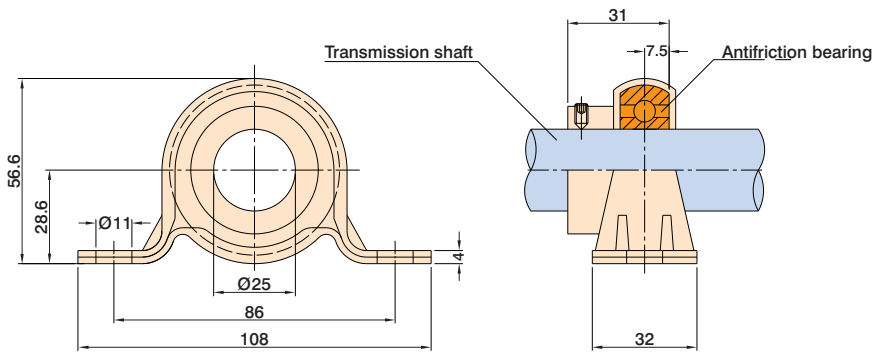

Pedestal bearing- to avoid vibrations/to support the transmission shaft (recommendable from a transmission shaft length of 1,500 mm up)	
Transmissible torque	18 Nm
Weight of coupling	0.3 kg
Weight of shaft	0.540 kg/m
Moment of inertia of both couplings	$2.68 \cdot 10^{-4} \text{ kgm}^2$
Moment of inertia of shaft	$8.171 \cdot 10^{-6} \text{ kgm}^2/100 \text{ mm}$

Dimensioned drawing - coupling

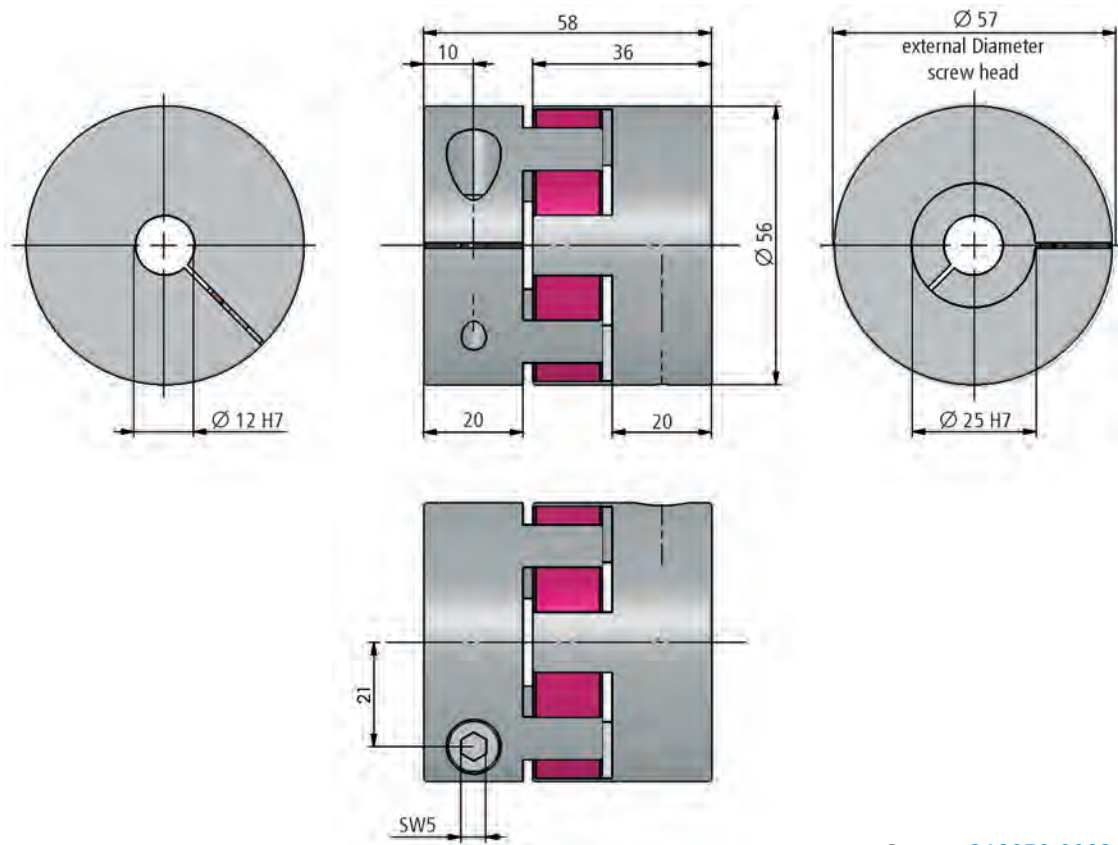

Part-no. **218050 0002**

Slide/crossbench plates

Connectors

Hole diagram, slide plate PS 1

L 125 x W 70 x H 7.7 mm

Mounting on:
LES 4 with 1 x WS 5/70

Part no.: **277001**

Connecting cross 2 x LES 4

Part no.: **277007**

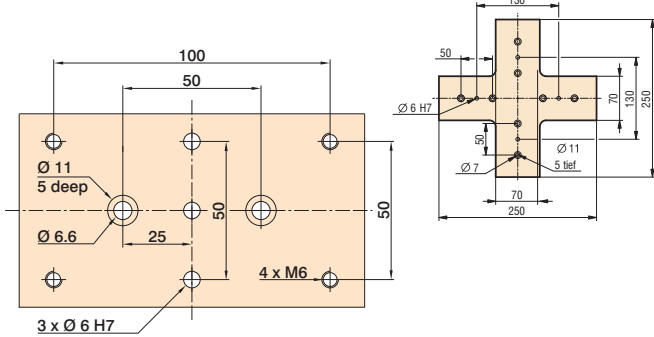

Hole diagram, slide plate PS 2

L 255 x W 70 x H 7.7 mm

Mounting on:
LES 4 with 2 x WS 5/70

Fixing option for:
Angle bracket WV 2 / WV 5

Part no.: **277002**

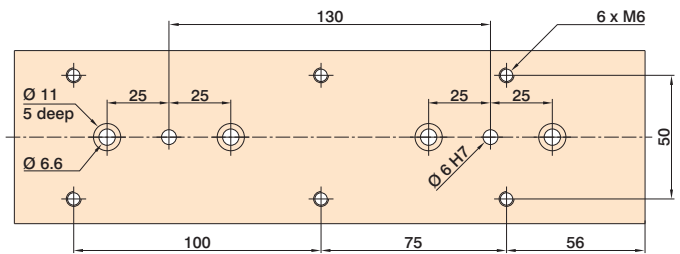

Hole diagram, slide plate PS 3

L 220 x W 125 x H 7.5 mm

Mounting on:
LES 5 with 2 x WS 5/70

Part no.: **277003**

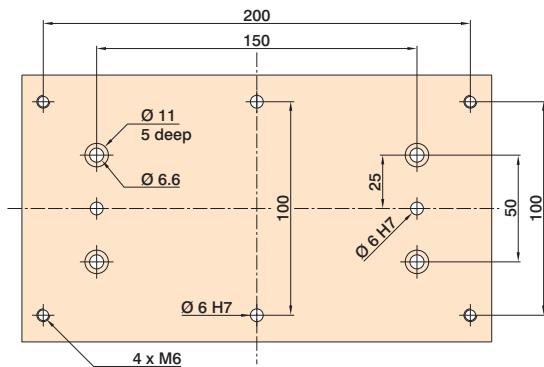

Hole diagram, slide plate PS 4

L 225 x W 220 x H 7.5 mm

Mounting on: LES 5 with 4 x WS 5/70
Mounting on crossbench: LES 5 with LES 5 (in conjunction with VP 2)
Fixing option for: Angle bracket WV 3 / WV 6

Part no.: **277004**

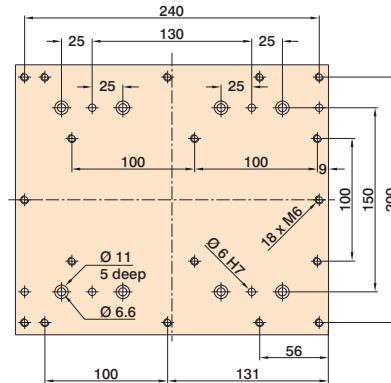

Hole diagram, slide plate PS 6

L 220 x W 125 x H 7.5 mm

Mounting on: LES 4 with 2 x WS 5/70
Mounting on crossbench: LES 4 with LES 5 (in conjunction with PS 3).
Fixing option for: LES 4/LES 5

Part no.: **277011**

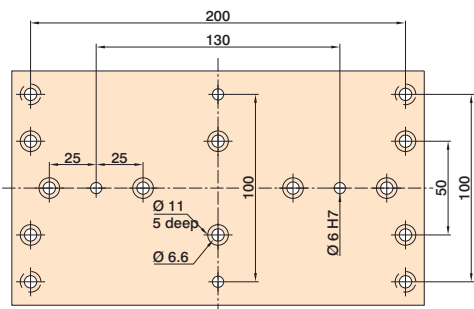

Hole diagram, slide plate PS 7

L 255 x W 220 x H 7.5 mm

Mounting on: LES 6 with 4 x WS 5/70
Mounting on crossbench: LES 6 with LES 5 (in conjunction with PS 4)

Part no.: **277016**

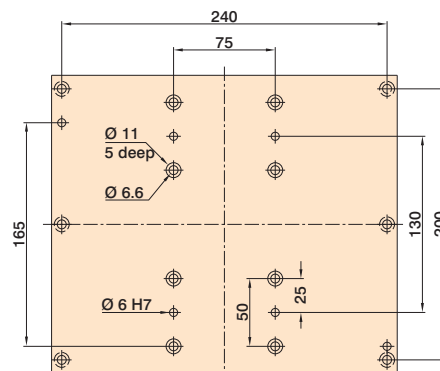

Slide/crossbench plates

Connectors

Hole diagram, slide plate PS 8

L 125 × W 145 × H 7.7 mm

Mounting on:

LES 6 with 2 × WS 5/70 **Part no.: 277017**

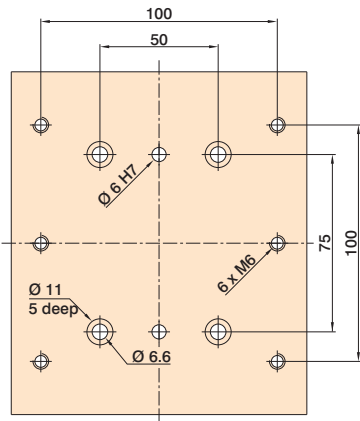

Hole diagram, slide plate PS 9

L 250 × W 145 × H 7.5 mm

Mounting on: LES 6 with 4 × WS 5/70

Fixing option for: Angle bracket WV 7

Part no.: 277018

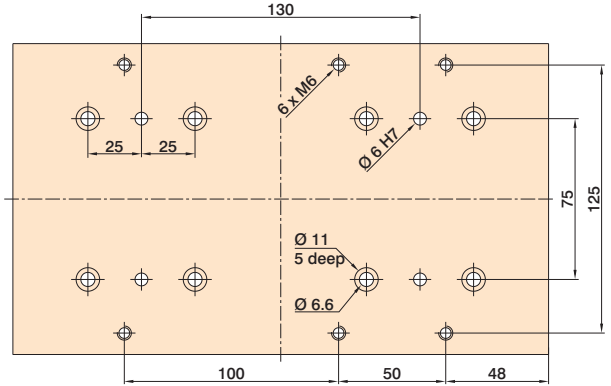

Hole diagram, slide plate PS 10

L 210 × W 215 × H 7.5 mm

Mounting on: LES 6 with 4 × WS 5/70

Mounting on crossbench: LES 6 with LES 6 (in conjunction with PS 11)

Part no.: 277019

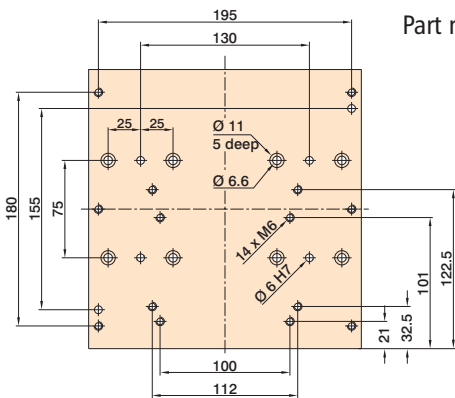

Hole diagram, slide plate PS 11

L 210 × W 215 × H 7.5 mm

Mounting on: LES 6 with 4 × WS 5/70

Mounting on crossbench: LES6 with LES4 (in conjunction with PS10) Fixing option for: LES 6

Part no.: 277020

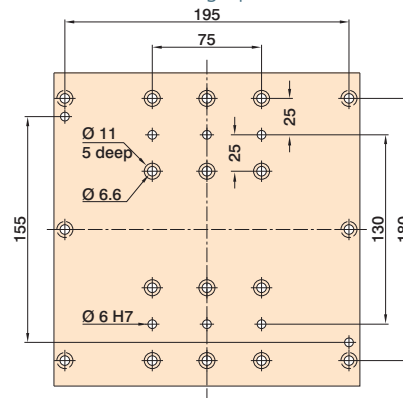

Hole diagram, slide plate PS 12

L 220 × W 180 × H 7.5 mm

Mounting on: LES 6 with 4 × WS 5/70

Fixing option for: LES 5 **Part no.: 277021**

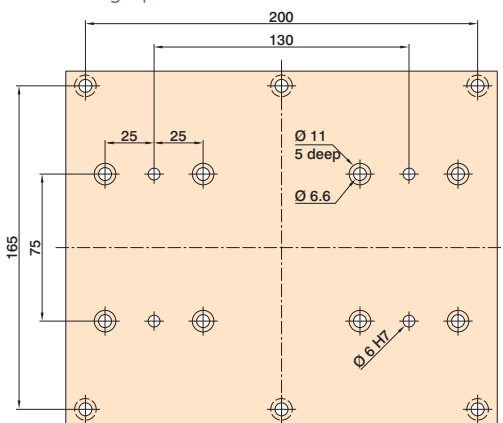

Hole diagram, connection plate VP 2

L 255 × W 220 × H 7.5 mm

Mounting on: LES 5 with 4 × WS 5/70

Fixing option for: LES 5

Part no.: 277006

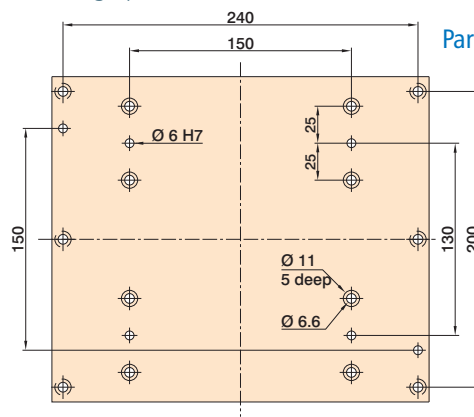

Slide/crossbench plates

Connectors

Hole diagram, slot plate set for crossbench LES 4

L 100 × W 100 × H 8 mm

Mounting on: LES 4
Fixing option for: LES 4

Part no.: **277008**

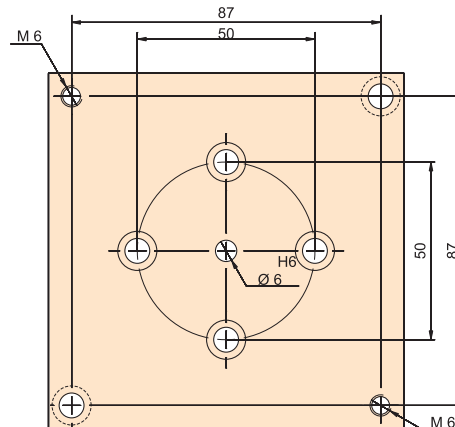

Crossbench connection plates 1

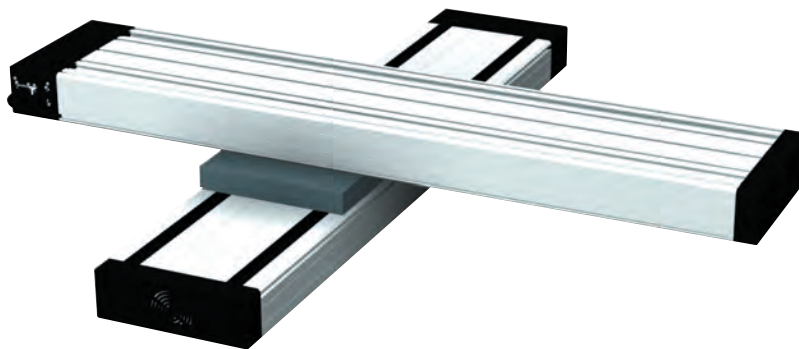

Crossbench connection plates 1

2 × L 255 × W 220 x H 8 mm

one set from PS 4 and VP 2,
for right-angled connection
two linear guides LES 5

Part no.: **277010**

Crossbench connection plates 2

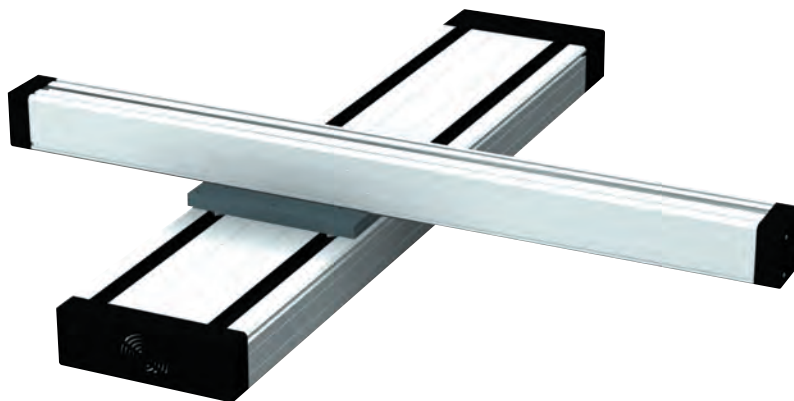

Crossbench connection plates 2

2 × L 220 × W 125 x H 8 mm

one set from PS 3 and PS 6,
for right-angled connection
one linear guide LES 5 with one
linear guide LES 4

Part no.: **277012**

Additional combination examples

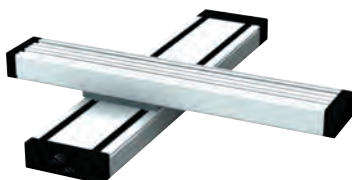

Crossbench LES 5 and LES 6
PS 4 and PS 7



Crossbench 2 x LES 6
PS 10 and PS 11



Crossbench LES 4 and LES 6
PS 11 and PS 10

T-slot slide plates

Connectors

Hole pattern T-slot plate PT 25 × 250 for LES 4

L 100 × W 75 × H 20 mm

Mounting on: LES 4 with 1 × WS 5/70

Part no.: **277030 0001**

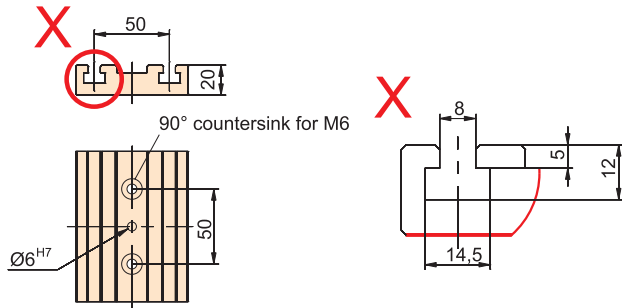

L 200 × W 75 × H 20 mm

Mounting on: LES 4 with 2 × WS 5/70

Part no.: **277030 0002**

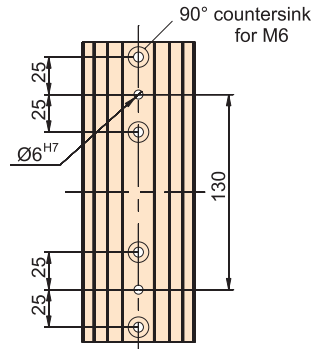

Hole pattern T-slot plate PT 25 × 250 for LES 6

L 100 × W 125 × H 20 mm

Mounting on: LES 6 with 2 × WS 5/70

Part no.: **277030 0003**

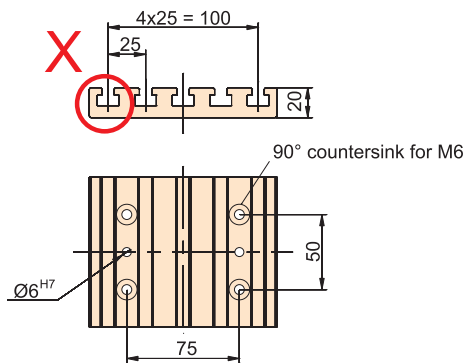

L 200 × W 125 × H 20 mm

Mounting on: LES 6 with 4 × WS 5/70

Part no.: **277030 0004**

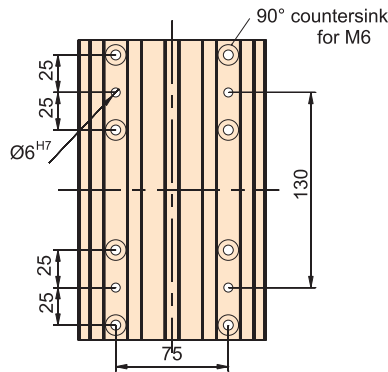

Hole pattern T-slot plate PT 25 × 250 for LES 5

L 100 × W 250 × H 20 mm

Mounting on: LES 5 with 2 × WS 5/70

Part no.: **277030 0005**

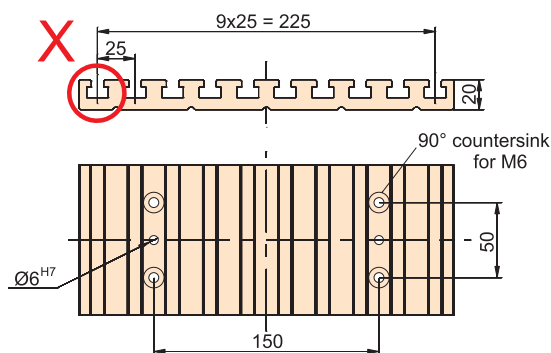

L 200 × W 250 × H 20 mm

Mounting on: LES 5 with 4 × WS 5/70

Part no.: **277030 0006**

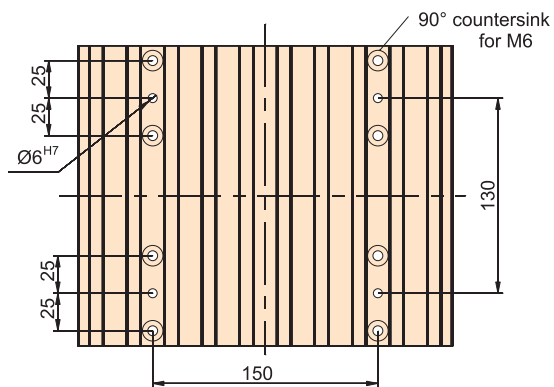

Angle brackets

Connectors

Angle bracket with clamping surface milled flat

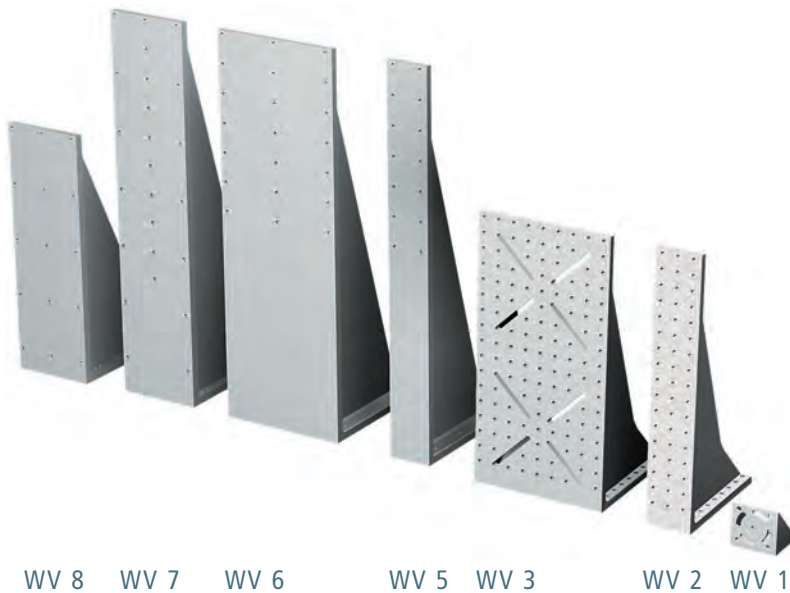

WV 8 WV 7 WV 6 WV 5 WV 3 WV 2 WV 1

matching cover plates

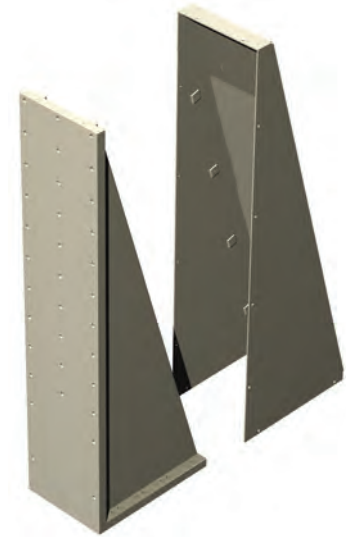

Angle bracket WV 1

- blank
 - Aluminium casting (0.2 kg)
 - $L71 \times W75 \times H71$
- Part no.: **209110 0010**

Angle bracket WV 2

- blank
 - Aluminium casting (2.6 kg)
 - $L221 \times W75 \times H446$
- Part no.: **209110 0022**

Angle bracket WV 3

- blank
 - Aluminium casting (1.1 kg)
 - $L221 \times W221 \times H446$
- Part no.: **209110 0032**

Angle bracket WV 5

- blank
 - Aluminium, welded (5.3 kg)
 - $L220 \times W75 \times H670$
- Part no.: **209110 0050**

Angle bracket WV 6

- blank
 - Aluminium, welded (13.3 kg)
 - $L220 \times W220 \times H670$
- Part no.: **209110 0060**

Angle bracket WV 7

- blank
 - Aluminium, welded (10.8 kg)
 - $L220 \times W220 \times H670$
- Part no.: **209110 0070**

Angle bracket WV 8

- blank
 - Aluminium, welded (7.4 kg)
 - $L222 \times W145 \times H446$
- Part no.: **209110 0080**

Angle bracket WV 19

- blank
 - Aluminium, welded (2.5 kg)
 - $L150 \times W221 \times H300$
- Part no.: **209110 0190**

Cover plate for WV 2

- naturally anodised
 - Aluminium sheet, weight 0.8 kg
- Part no.: **209110 0021**

Cover plate for WV 3

- naturally anodised
 - Aluminium sheet, weight 1.15 kg
- Part no.: **209110 0031**

Cover plate for WV 5

- naturally anodised
 - Aluminium sheet, weight 1.2 kg
- Part no.: **209110 0051**

Cover plate for WV 6

- naturally anodised
 - Aluminium sheet, weight 1.8 kg
- Part no.: **209110 0061**

Cover plate for WV 7

- naturally anodised
 - Aluminium sheet, weight 1.5 kg
- Part no.: **209110 0071**

Cover plate for WV 8

- naturally anodised
 - Aluminium sheet, weight 1 kg
- Part no.: **209110 0081**

Angle brackets

Connectors

Hole diagram

Angle bracket WV 1

L 71 × W 75 × H 71 mm

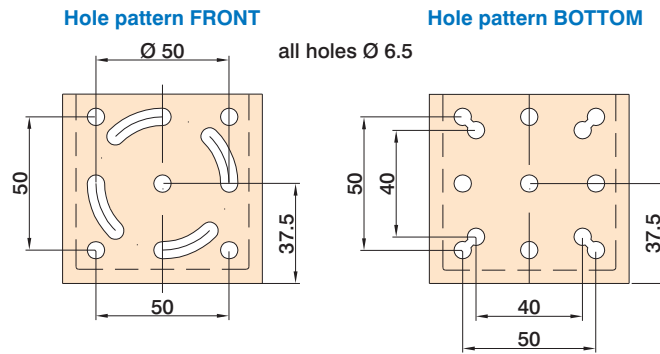

Hole diagram

Angle bracket WV 2

L 221 × W 75 × H 446 mm

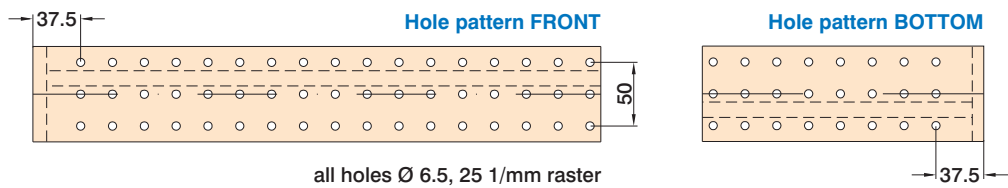

Hole diagram

Angle bracket WV 3

L 221 × W 221 × H 446 mm

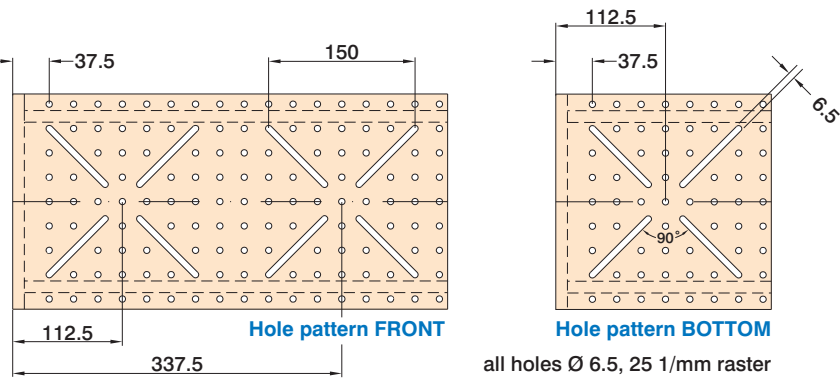

Hole diagram

Angle bracket WV 5

L 220 × W 75 × H 670 mm

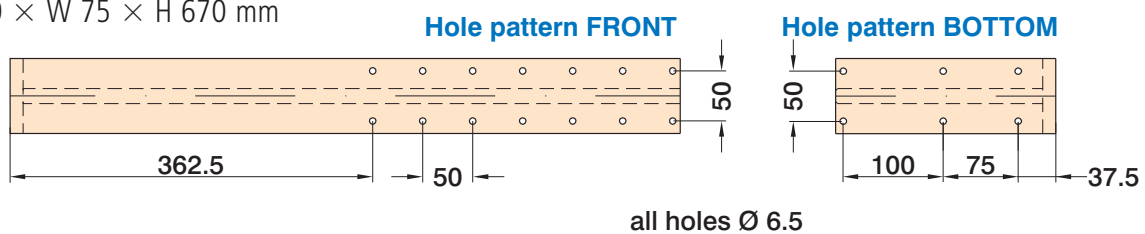

Angle bracket

Connectors

Hole diagram

Angle bracket WV 6

L 220 × W 220 × H 670 mm

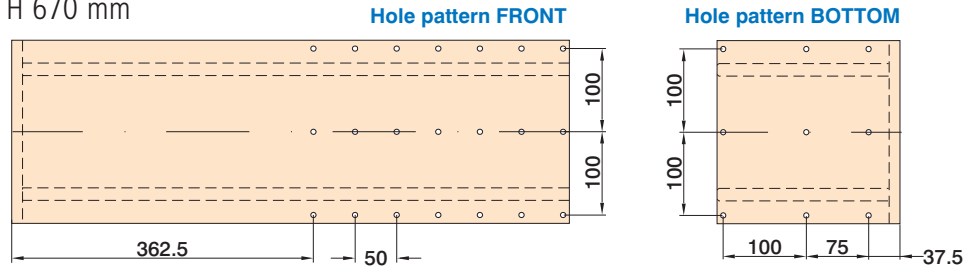

Hole diagram

Angle bracket WV 7

L 220 × W 145 × H 670 mm

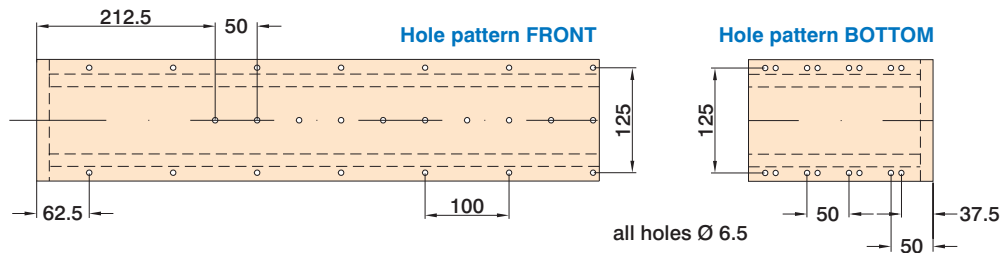

Hole diagram

Angle bracket WV 8

L 222 × W 145 × H 446 mm

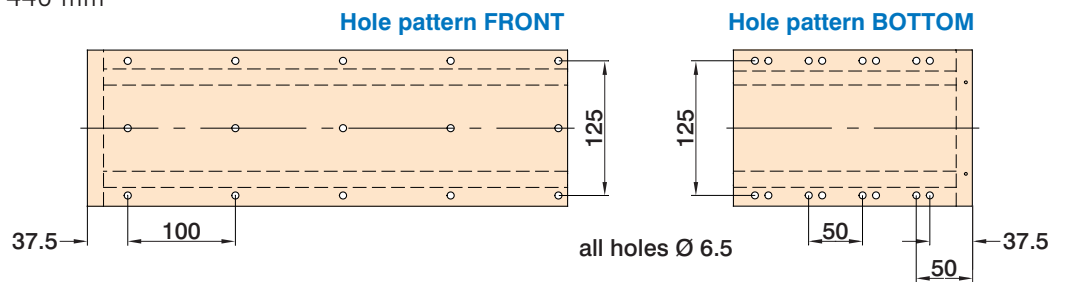

Hole diagram

Angle bracket WV 19

L 150 × W 221 × H 300 mm

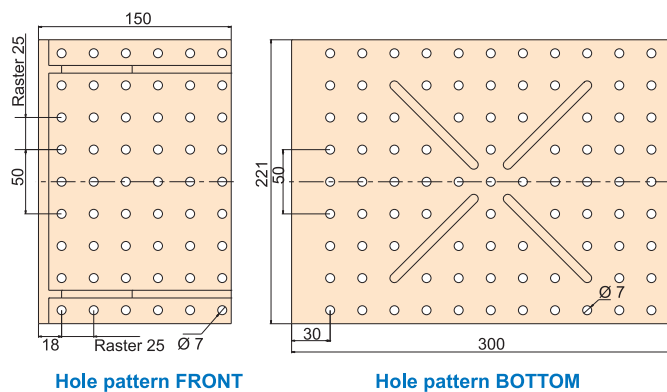

Accessories

Energy guidance chain



Dimensioned drawing
Energy guide chain

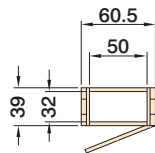

Energy guide chain 3

- VE 1 pc. at 1 m
- Part no.: **219204 1000**

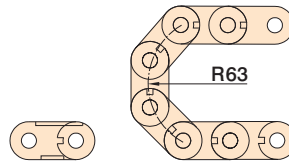

Connectors for energy chain 3

- with strain relief
- VE 1 kit
- Part no.: **219205 0002**

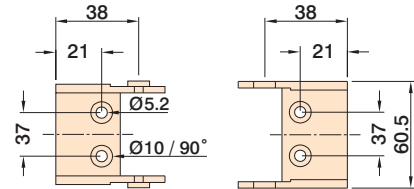

Tapped strips / sliding nuts

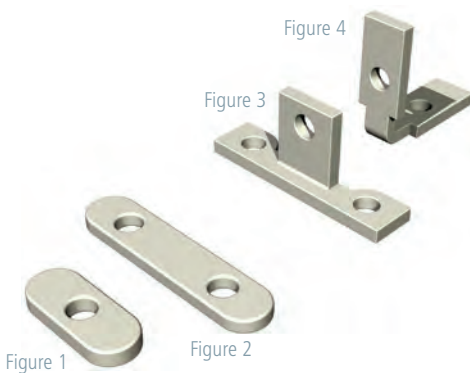

Tapped strips M6 (no figure)

- galvanised
- Ra 50 mm
- VE 3 pcs. at 1 m
- Part no.: **209011**

Sliding nut 2 × M6 (Figure 2)

- galvanised
- VE 50 units
- Part no.: **209002 0004**

Special angle sliding nut 3 × M6 (Figure 3)

- galvanised
- VE 25 pcs.
- Part no.: **209022 0003**

Sliding nut M6 (Figure 1)

- galvanised
- VE 100 pcs.
- Part no.: **209001 0005**

Angle sliding nut 2 × M6 (Figure 4)

- galvanised
- VE 25 pcs.
- Part no.: **209021 0003**

Sliding nut M5 (no figure)

- galvanised
- VE 20 pcs.
- Part no.: **209006 0001**

Attachment kits

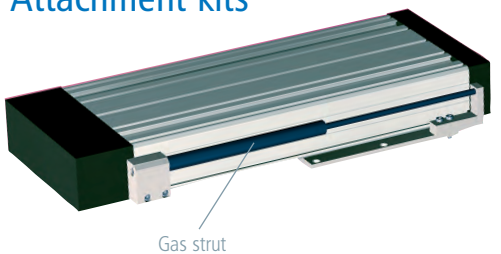

Gas strut attachment kit

- Stroke 220 mm
- Nominal length 490 mm
- Part no.: **216450 0001**

Gas strut attachment kit

- Stroke 300 mm
- Nominal length 690 mm
- Part no.: **216451 0001**

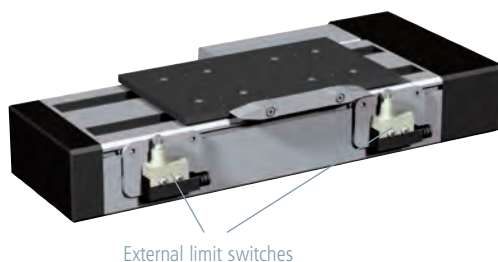

Limit switch attachment kit for LES 4

- for external limit switches
- Process path reduction by appr. 40 mm
- Part no.: **216460 0001**

Limit switch attachment kit LES 6

- for external limit switches
- Process path reduction by appr. 40 mm
- Part no.: **216460 0003**

Limit switch attachment kit LES 5

- for external limit switches
- Process path reduction by appr. 40 mm
- Part no.: **216460 0002**

Mounting set for sealing air

- for LF4 - LF6
- Part no.: **216460 0006**

Cross bench 10/20

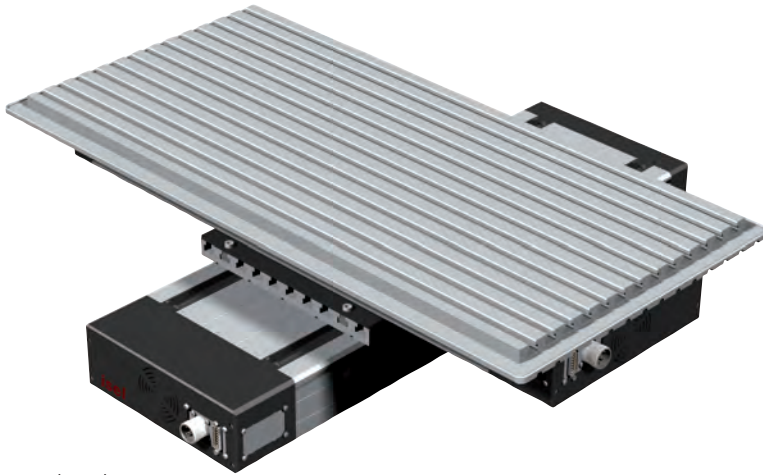

Crossbench 20
With milled T-key plate and drainage channel (option)

Features

- Two isel linear units LES 5 adjustable for no play with integrated servomotor
- Recirculating ball drive, pitch 10 mm
- Travel:
X-axis: 210/310 mm
Y-axis: 210/310 mm
- Options:
 - 5 mm spindle pitch
 - Milled T-slot plate
 - step motor
 - Servo controller
 - Other travel

The crossbenches 10/20 consist of two linear units LES 5, which are interconnected at right angles. The individual axes are driven by servo motor with a recirculating ball drive of 10 mm pitch.

To achieve very high load-bearing capabilities, each axis is fitted with four linear slots.

In addition to this standard design, it is possible to combine all LES 5 linear units with each other by means of the crossbench connection plates.

Ordering data

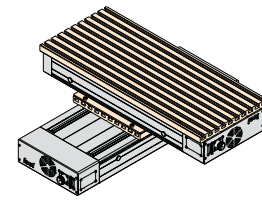

Crossbench 10-V
Part no.:
272200 0001

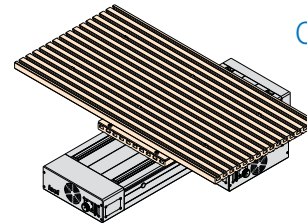

Crossbench 20-V
Part no.:
272200 0002

Dimensioned drawings

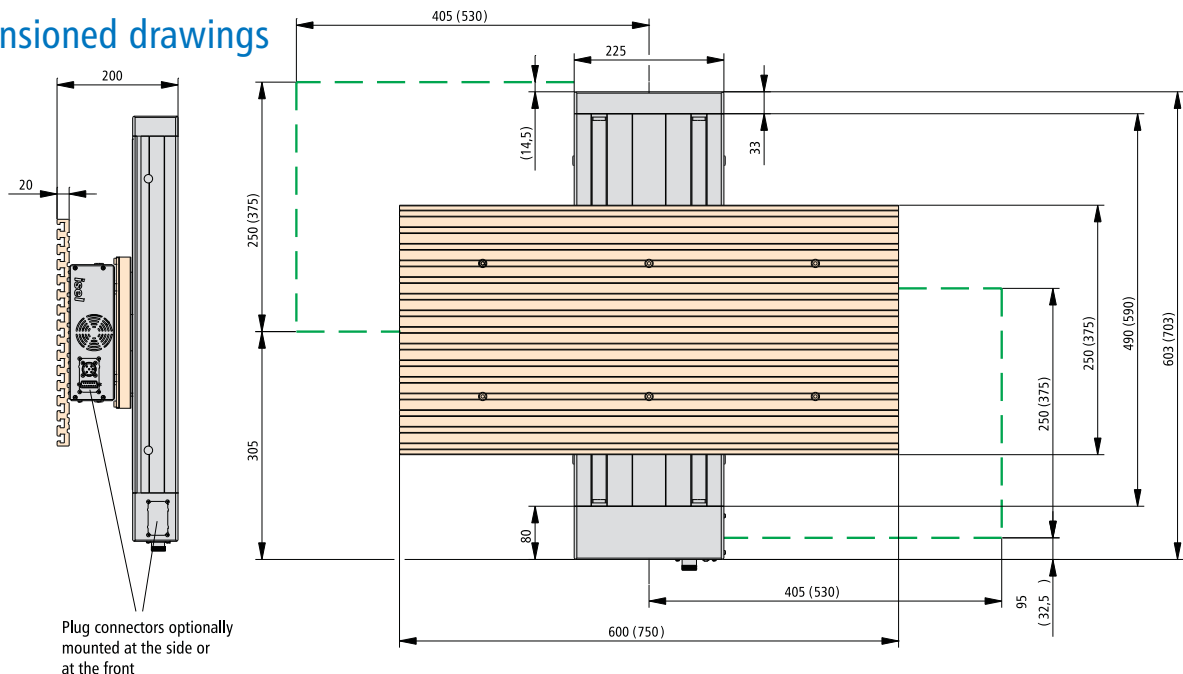

Space for your notes

Functional overview Linear unit LEZ 9

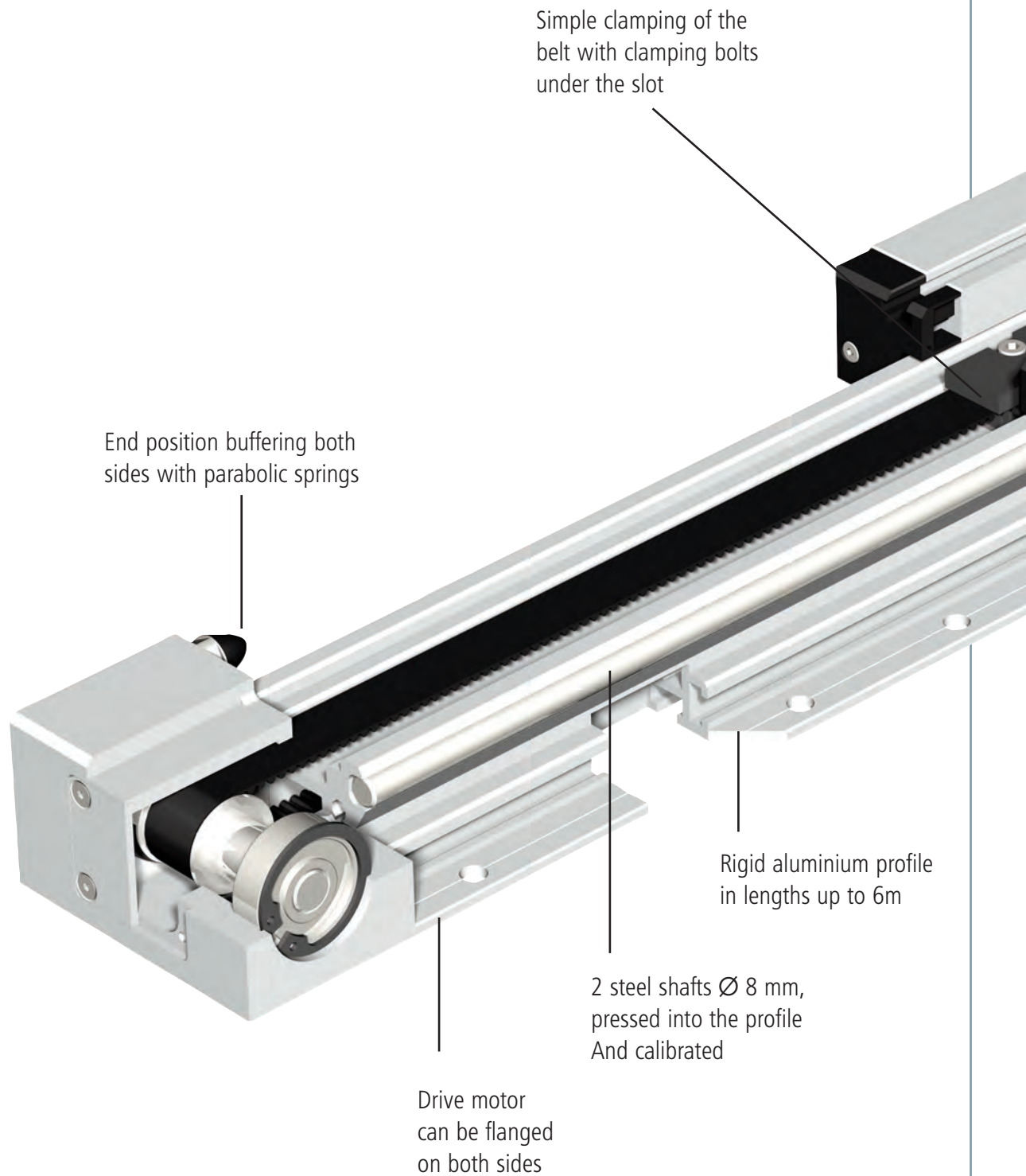

Functional overview Linear unit LEZ 9

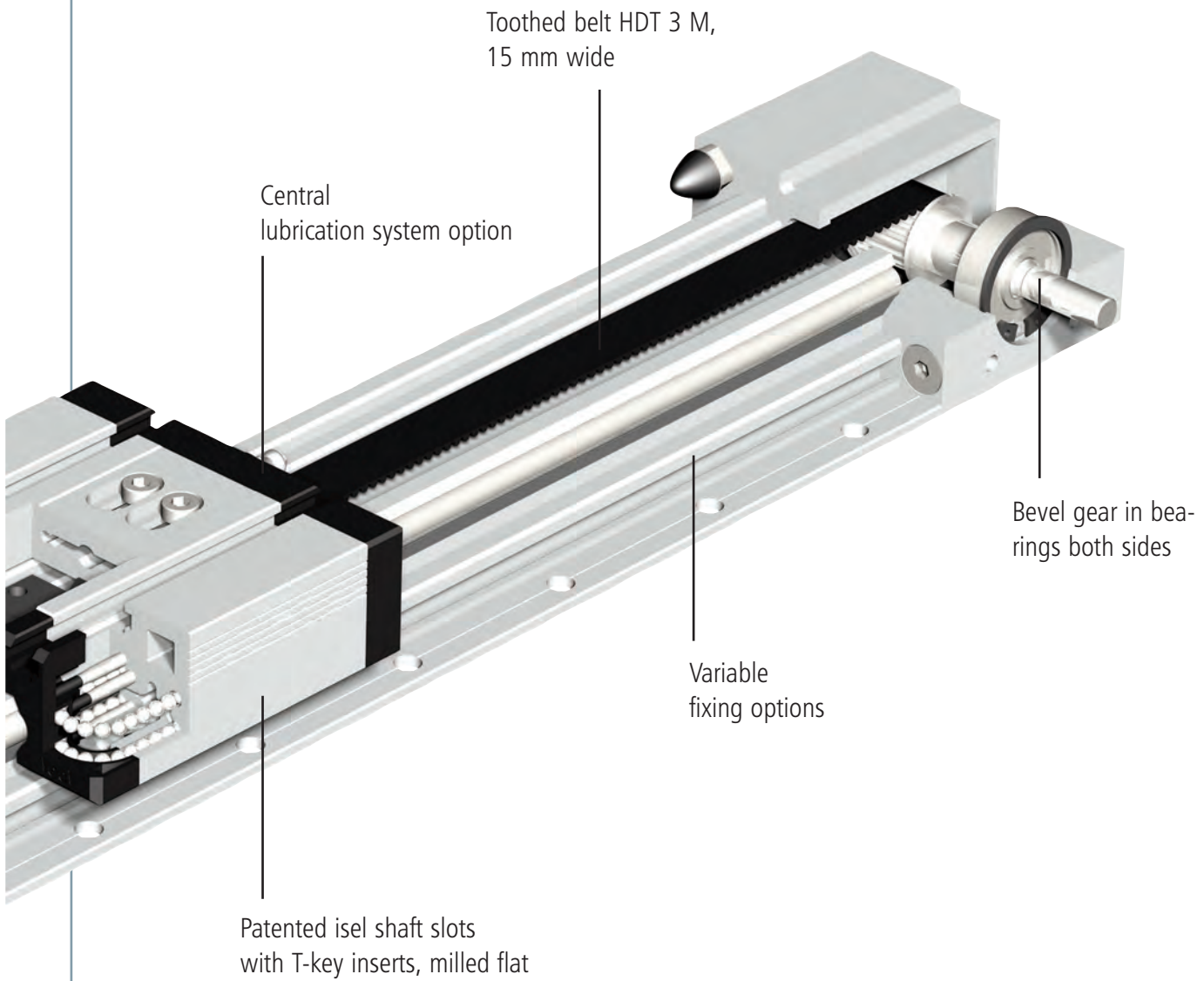

Linear units with toothed belt drive

LEZ 1

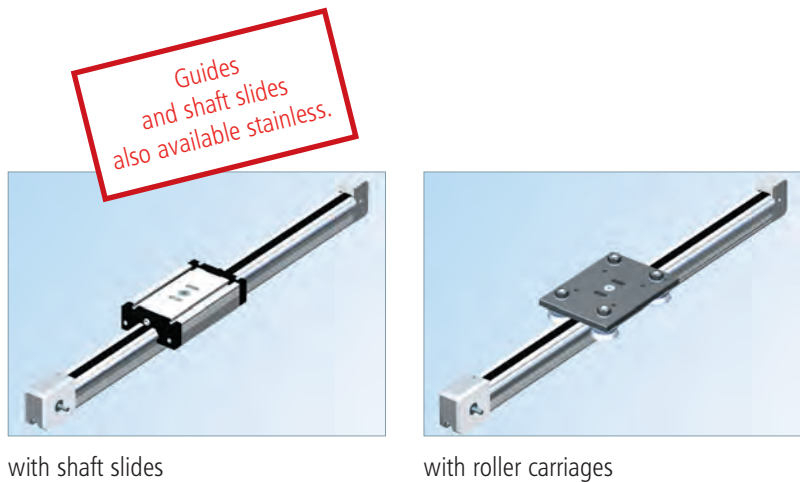

Features

- Aluminium profile, miniature linear guide LFS-8-2
- no-play feed with toothed belt drive
 - toothed belt with 3 mm interval
 - Width 9 mm
- Feed per turn: 60 mm
- Repeatability less than or equal to ± 0.2 mm
- Max. feed. 1,5 m/s
- Limit or reference switch accuracy < 0,1 mm (with drive modules)

Accessories are on page C98.

Options:

- special lengths in 100 mm raster to order, max. 6000 mm
- Also available as direct drive with
 - step motor
 - DC servo motor
- Overrun limit switches with connecting cable (only in combination with integrated drive module)

Ordering key

232 005 XXXX

<p>Drives/Slides</p> <p>Roller carriages</p> <p>8 = without motor, with shaft slides</p> <p>9 = without motor, with roller carriages</p>	<p>Profile lengths LFS-8-2 (mm)</p> <p>298, 398, 498, 598, 675, 698, 798, 998, 1498, 1798, 1998, 2498, 2998</p> <p>(e. g. 398 mm = 040 675 mm = 068)</p> <p>Option: up to 6000 mm</p>
--	--

Technical specification

Belt type.....	HTD 3M, width 9 mm
Slide weight.....	0.430 kg
Weight without drive module.....	1000 mm = 3 kg
specific weight of the toothed belt.....	0.0225 kg/m
Roller carriage weight.....	1.03 kg
specific guide weight.....	0.200 kg/100 mm
Effective diameter of the synchronous disks.....	$\varnothing 19.10$ mm
Moment of inertia of the synchronous disks.....	$5.585 \cdot 10^{-7}$ kgm ²
Feed per turn.....	60 mm

Load diagram

Permitted accelerated weights relative to the belt strength.*

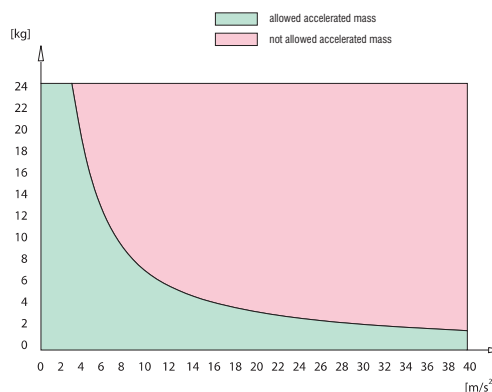

* with vertical construction, the acceleration due to gravity ($g = 9.81$ m/s²) must be taken into account

Bending data is on page C 23.

Linear units

with toothed belt drive

LEZ 1

Dimensioned drawings

without motor, with shaft slides

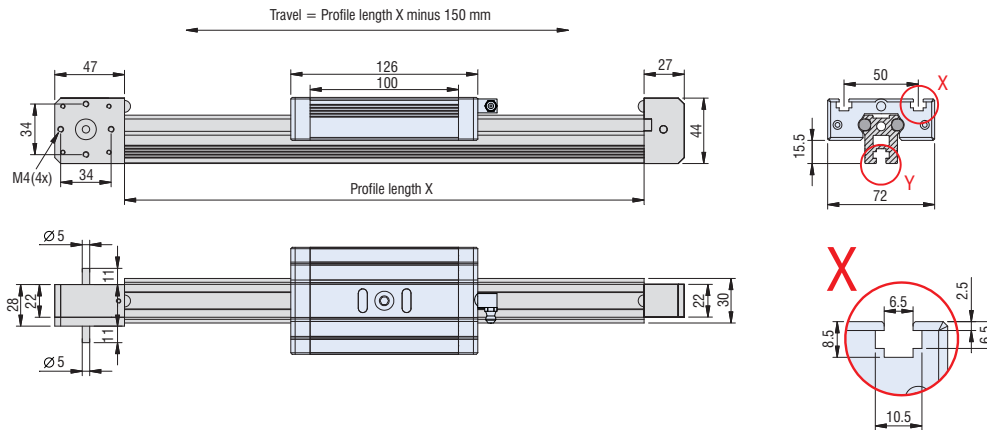

without motor, with roller carriages

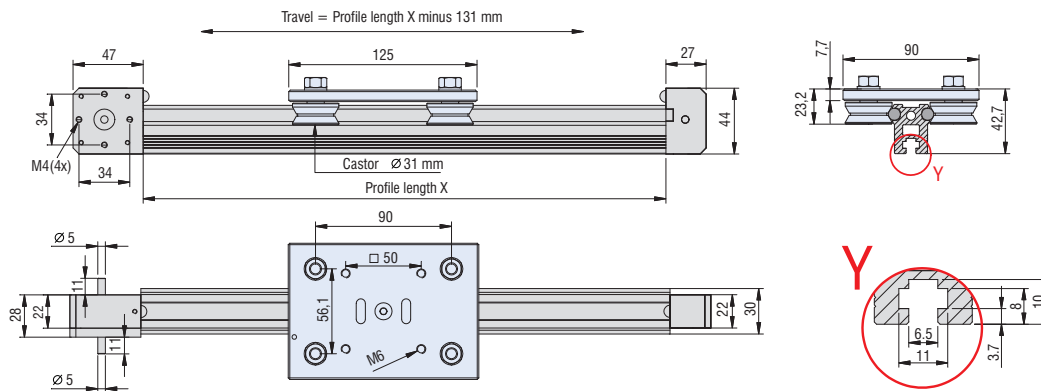

Motor modules (Motor pin assignments are on page C74.)

Drive module with step motor
MS-045 HT (direct drive)
Feed: 60 mm/turn

Part no.: **396048 3015**

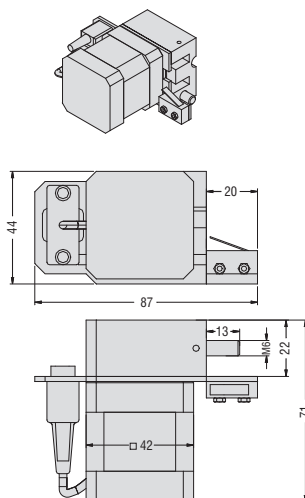

Drive module with step motor
MS-045 HT (reduction 2:1)
Feed: 30 mm/turn

Part no.: **396049 3015**

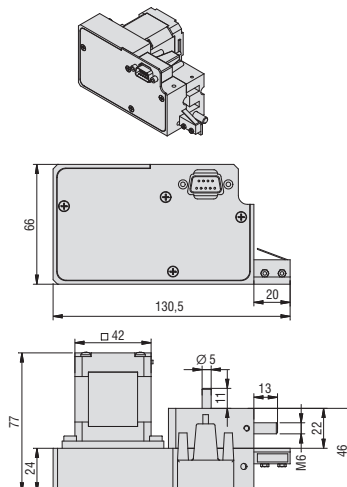

Drive module with step motor
MS-135 HT (reduction 2:1)
Feed: 30 mm/turn

Part no.: **396056 3015**

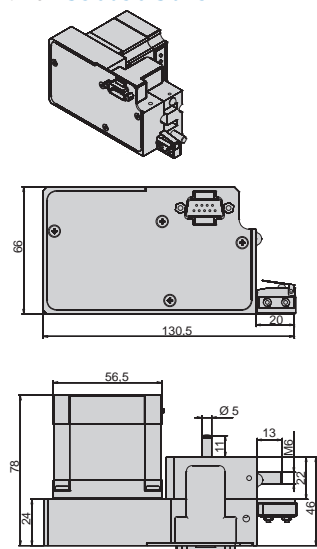

Linear units with toothed belt drive

LEZ 2

Guides and shaft slides also available stainless.



with shaft slides

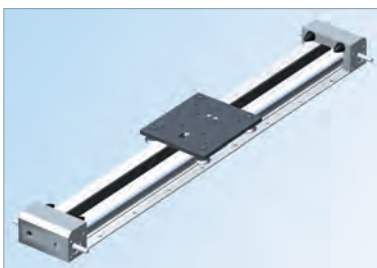

with roller carriages

Features

- Aluminium profile, with miniature linear guide LFS-8-5
- no-play feed with toothed belt drive - toothed belt with 5 mm interval, Width 25 mm
- Max. feed. 5 m/s
- Shaft slides WS 3, L 176 × W 130 mm
- Feed per turn: 70 mm
- Repeatability less than or equal to ± 0.2 mm
- Limit or reference switch accuracy < 0.1 mm
- available in lengths up to 6,000 mm

Accessories are on page C98.

Options:

- Special lengths in 100 mm raster to order, max. 6,000 mm
- also as direct drive with
 - Multi-phase motor
 - DC servomotor
- Overrun limit switches with connecting cable (only in combination with integrated drive module)

Ordering key

232 002 XXXX

Profile lengths (mm)
696, 996, 1496, 1996,
2496, 2996
(e. g. 696 mm = 070
1496mm = 150)
Option: up to 6000 mm

Drive/Slides, Roller carriages
8 = without motor, with shaft slides
9 = without motor, with roller carriages

Technical specification

Belt type..... HTD 5M, width 25 mm
Slide weight..... 0,940 kg
Weight without drive module..... 1000 mm $\hat{=}$ 7.9 kg
specific weight of the toothed belt..... 0.09 kg/m
Roller carriage weight..... 2.03 kg
specific guide weight..... 0.472 kg/100 mm
Effective diameter of the synchronous disks..... \varnothing 22.28 mm
Moment of inertia of the synchronous disks..... $5.58 \cdot 10^{-6}$ kgm²
Feed per turn..... 70 mm

Linear guide rail LFS-8-5

Moment of inertia I_x 137,48 cm⁴
Moment of inertia I_y 27,98 cm⁴
Resistance torque W_x 23,91 cm³
Resistance torque W_y 13,09 cm³

Load diagram

Permitted accelerated weights relative to the belt strength.*

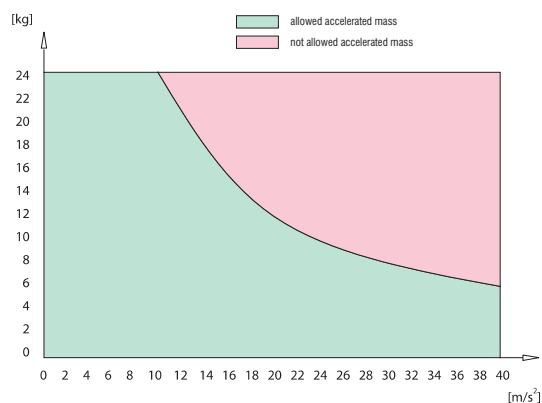

* with vertical construction, the acceleration due to gravity ($g = 9.81 \text{ m/s}^2$) must be taken into account

Linear units

with toothed belt drive

LEZ 2

Dimensioned drawings

without motor, with shaft slides

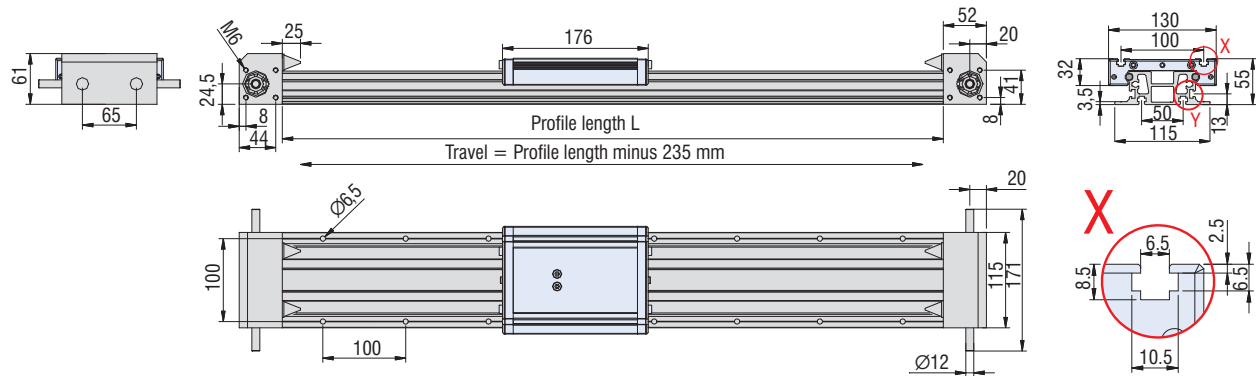

without motor, with roller carriages

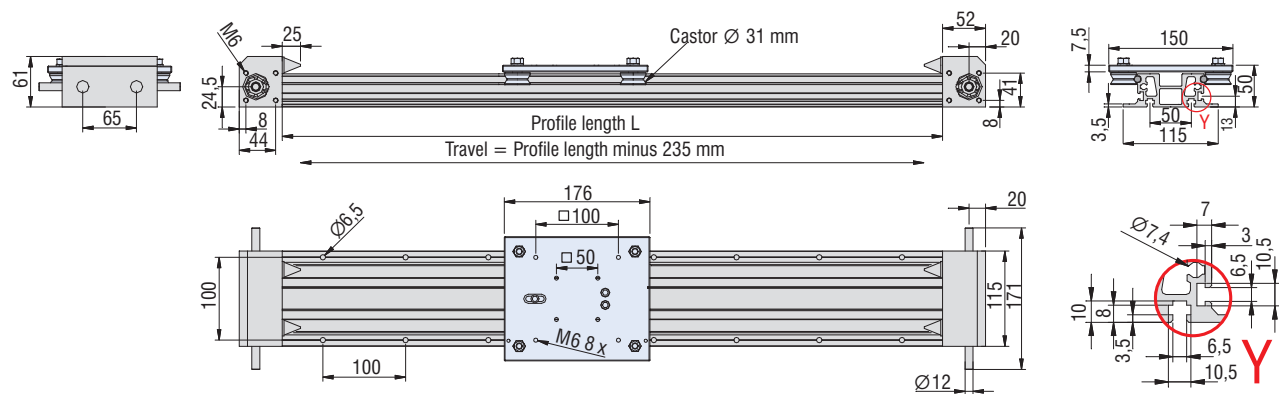

Motor modules (Motor pin assignments are on page C74.)

Drive module with step motor
MS-600 HT (reduction 2:1)
Feed: 35 mm/turn

Part no.: **396086 3060**

Drive module with EC servomotors
(Reduction 2:1)
Feed: 35 mm/turn

Part number	Motor module	Length L
396 415 3260	EC 60S with brake	151.5 mm
396 415 3060	EC 60S without brake	198.5 mm
396 423 3060	EC 60L	186.5 mm
396 444 3070	EC 86S	177.5 mm
396 466 3070	EC 86L	202.5 mm

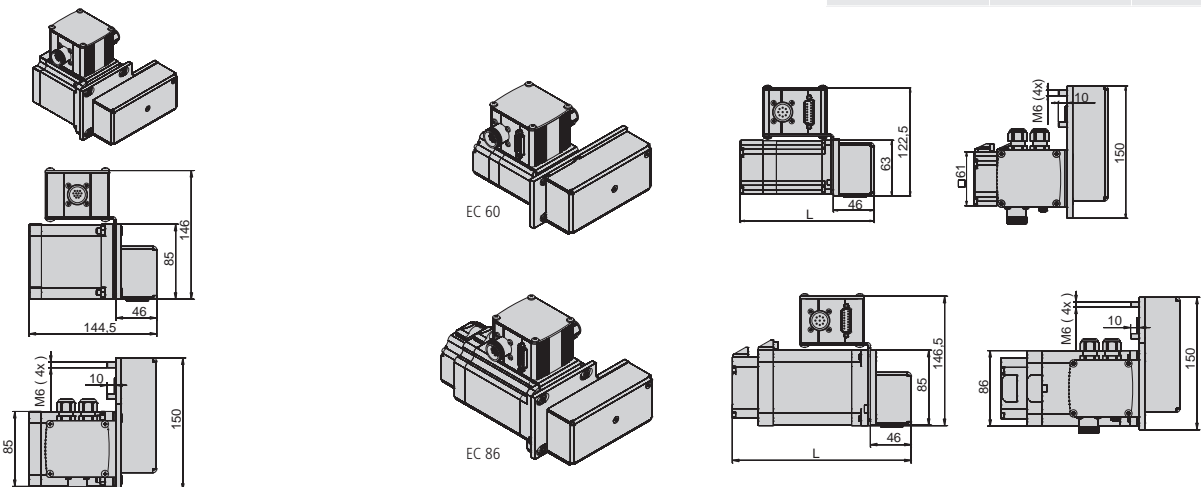

Linear units with toothed belt drive

LEZ 3

Guides and shaft slides also available stainless.



with shaft slides



with roller carriage

Features

- Aluminium profile, miniature linear guide LFS-8-4
- no-play feed with toothed belt drive, toothed belt with 5 mm interval, width 25 mm
- Max. feed. 5 m/s
- Shaft slides WS3, L176 × W130 mm
- Feed per turn: 70 mm or 150 mm
- Repeatability less than or equal to ± 0.2 mm
- Limit or reference switch accuracy < 0.1 mm
- available in lengths up to 6,000 mm
- Motor modules right and left can be flanged

Accessories are on page C98.

Options:

- Special lengths in 100 mm raster to order, max. 6,000 mm
- Overrun limit switches with connecting cable (only in combination with integrated drive module)

Ordering key

23200X XXXX

Profile lengths (mm)

698, 998, 1498, 1998, 2498, 2998

(e. g. 698 mm = 070

1498 mm = 150)

Feed

6 = 150 mm / turn

7 = 70 mm / turn

Slides, roller carriages

0 = with shaft slides

1 = with roller carriages

Technical specification

Belt type.....	HTD 5M, width 25 mm
Slide weight.....	0.940 kg
Weight without drive module.....	1000 mm [∧] = 10.5 kg
specific weight of the toothed belt.....	0.09 kg/m
Roller carriage weight.....	2.03 kg
specific guide weight.....	0.648 kg/100 mm
Feed per turn.....	70 mm or 150 mm
Effective diameter of the synchronous disks	
Feed 70 mm/turn.....	22.28 mm
Feed 150 mm/turn.....	47.75 mm
Moment of inertia of the synchronous disks	
Feed 70 mm/turn.....	5.58E-6 kgm ²
Feed 150 mm/turn.....	1,796.10 ⁻⁴ kgm ²

Load diagram

Permitted accelerated weights relative to the belt strength.*

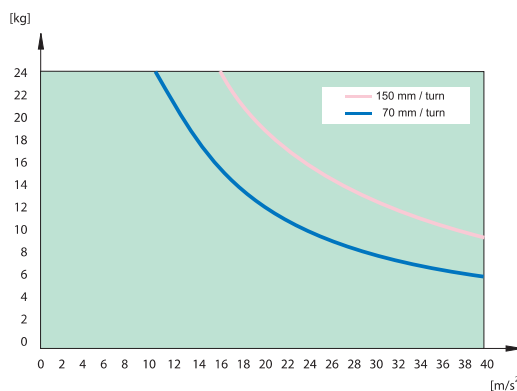

* with vertical construction, the acceleration due to gravity (g=9.81 m/s²) must be considered

Bending data is on page C 27.

Linear units

with toothed belt drive

LEZ 3

Dimensioned drawings

with shaft slides

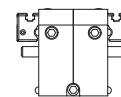
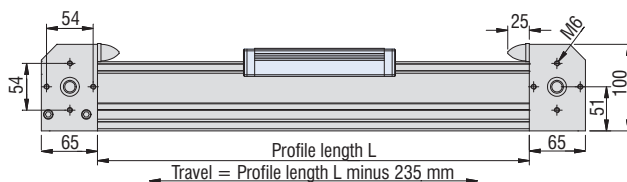
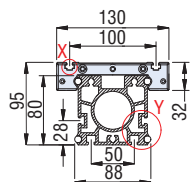

Feed: 70 mm/turn

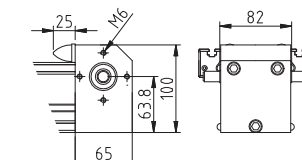
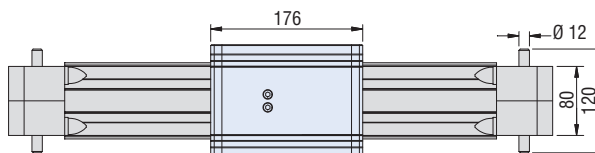
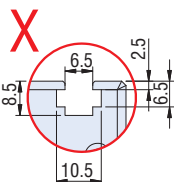

with roller carriages

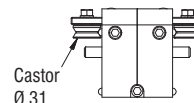
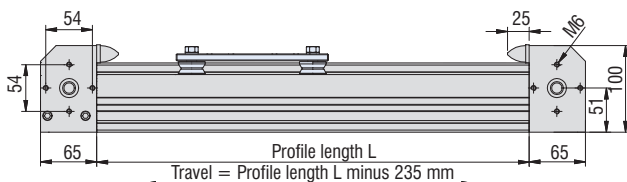
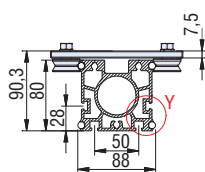

Feed: 70 mm/turn

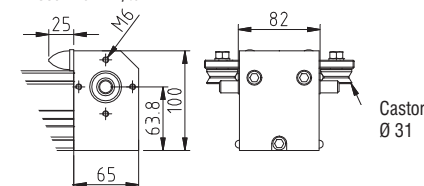
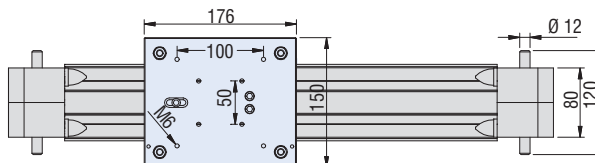
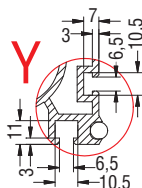

Motor modules (Motor pin assignments are on page C74.)

Drive module with stepper motor (direct drive)

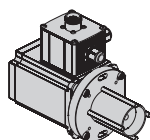

Part number	Motormodul	
396 085 0060	MS 600 HT	right
396 085 0061	MS 600 HT	left
396 088 0060	MS 900 HT	right
396 088 0061	MS 900 HT	left

Drive module with EC servomotor EC 86 (direct drive)

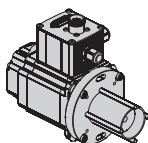

Part number	Motor module	Length L
396 444 0070	EC 86S	177.5 mm
396 466 0070	EC 86L	202.5 mm

Drive module with DC servomotor DC 300 (direct drive)
Part no.: **396114 0060**

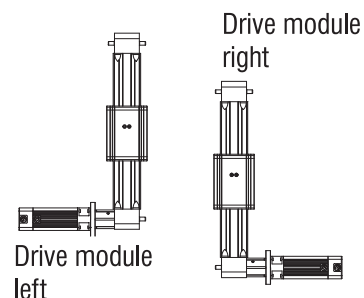
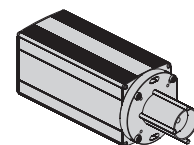

Linear units with toothed belt drive

LEZ 9

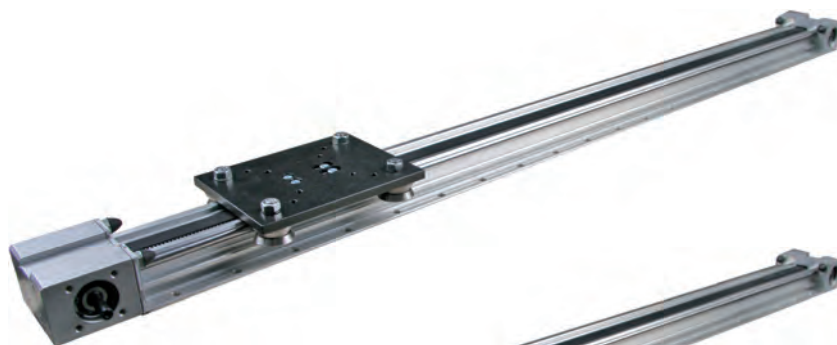

with roller carriages



with shaft slides

Features

- Aluminium profile
Linear guide LFS-8-7
- no-play feed with
toothed belt drive
- toothed belt with 3 mm interval
Width 15 mm
- Max. feed. 2 m/s
- Shaft slides WS 11
L 96 × W 95 mm
- Feed per turn: 60 mm
- Repeatability less than or
equal to ± 0,2 mm
- Limit or reference switch
accuracy < 0.1 mm
- Servomotor

Accessories are on page C98.

Options:

- Special lengths in 100 mm raster
to order
- Stepper motor

Ordering key

232010 XXXX*

Profile lengths (mm)

496, 996, 1496, 1996, 2496, 2996

(e. g. 496 mm = 0050

1496 mm = 0150)

Note:

Please order drive modules separately on the listed part numbers and specify here, whether the delivery should take place with or without attachment.

* Only for model with shaft slide (model with carriage on request)

Technical specification

Belt type..... HTD 3M, width 15 mm
 Slide weight.....0.4 kg
 Weight without drive module.....1000 mm = 4.4 kg
 specific weight of the toothed belt.....0.04 kg/m
 specific guide weight.....0.29 kg/100 mm
 Effective diameter
 of the synchronous disks..... Ø 19.1 mm
 Moment of inertia
 of the synchronous disks..... 5.58E-6 kgm²
 Feed per turn.....60 mm

Linear guide rail LFS-8-7

Moment of inertia I_x 29.34 cm⁴
 Moment of inertia I_y 10.86 cm⁴
 Resistance torque W_x 7.52 cm³
 Resistance torque W_y 5.68 cm³

Load diagram

Permitted accelerated weights relative to the belt strength.*

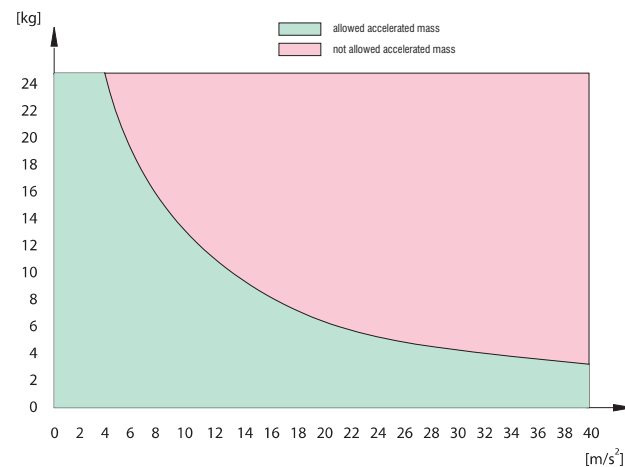

* with vertical construction, the acceleration due to gravity (g=9.81 m/s²) must be considered

Linear units

with toothed belt drive

LEZ 9

Dimensioned drawings

with shaft slides

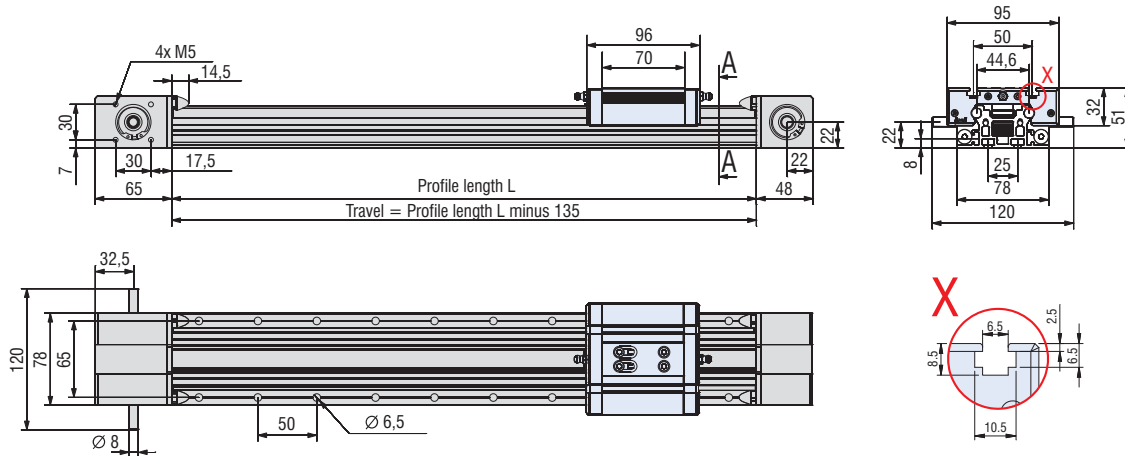

with roller carriages

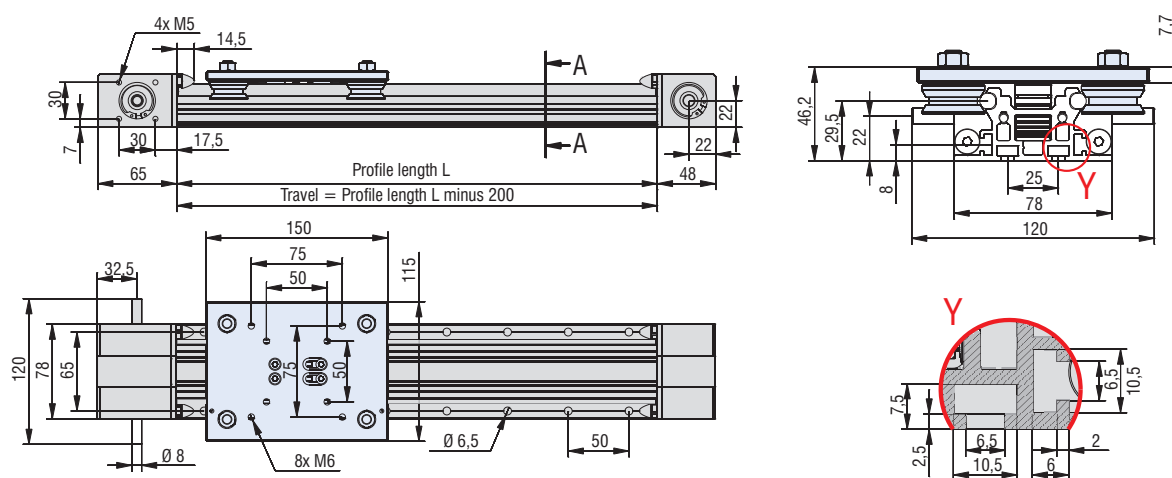

Motor modules (Motor pin assignments are on page C74.)

Drive module with stepper motor MS 200 HT
(Reduction 2:1)
Feed: 30mm / turn

Part number	Motor module	
396 058 3017	MS 200 HT	right
396 058 3018	MS 200 HT	left

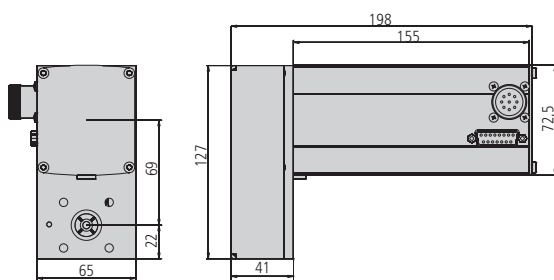
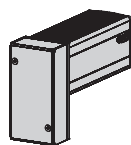

Drive module with DC servomotor DC 100
(Reduction 2:1)
Feed: 30mm / turn

Part no.: 396112 3063

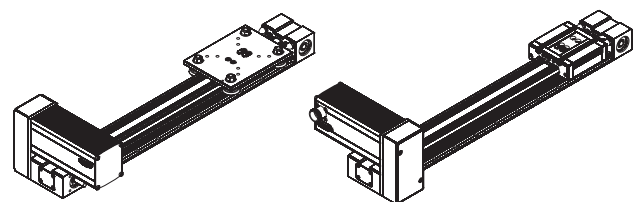
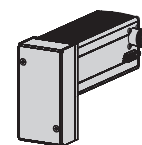
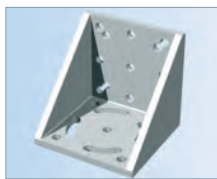

Figure:
LEZ 9 with roller carriage and MS 200 HAT stepper motor Mounted on left

Figure:
LEZ 9 with shaft slide and DC 100 servomotor mounted on right

Accessories

LEZ 1



Angle bracket

- for LEZ 1

Part no.: **209110 0010**



20/30 coupling

- for LEZ 1
- 1 VE = 1 coupling

Part no.: **218001 5080**

Shaft slide 1/70

- L 96 × W 72 × H 28.5 mm
- Clamping surface plane milled, T-slot insert, M6
- central lubrication system option, adjustable for no play
- Weight: 0.35 kg
- Option: stainless steel version

Part no.: **223 100 0070**
stainless steel: **223 101 0070**

Limit switch set

- Option: 2. Limit switches
- for LEZ 1

Part no.: **632 125 0002**

LEZ 2

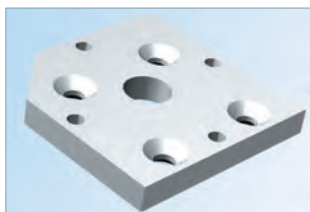

Motor fixing plate

- for LEZ 2
- incl. fixing material
- for direct drive see page C78 *et seq.*

Part no.: **232199 0004**

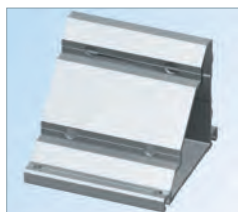

Angle bracket

- for LEZ 2
- incl. fixing material

Part no.: **232199 0005**

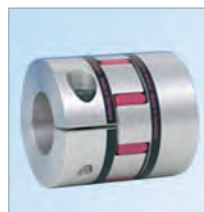

Coupling for Transmission shaft

- for LEZ 2
- 1 VE = 1 coupling

Part no.: **218003 0120**

LEZ 3

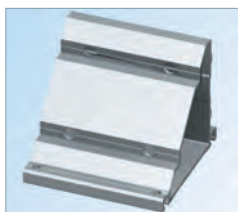

Angle bracket

- for LEZ 3
- incl. fixing material

Part no.: **232199 0005**



Coupling for transmissions shaft

- for LEZ 3
- 1 VE = 2 couplings

Part no.: **218050 0002**

Transmission shaft \varnothing 25 mm

Length 1m
Part no.: **219001 0125**

Length 2m
Part no.: **219001 0225**

Limit switch set

Motor side
Part no.: **397201 0000**
Deviation
Part no.: **397201 XXXX**

LEZ 9



30/40 coupling

- for LEZ 9
- 1 VE = 1 coupling

Part no.: **218002 8080**

Shaft slide WS 11/70

- L 96 × W 96 × H 32 mm
- Clamping surface plane milled, T-slot insert, M6
- central lubrication system option, adjustable for no play
- Weight: 0.4 kg
- Option: stainless steel version

Part no.: **223111 0070**
stainless: **223111 1070**

Examples in use

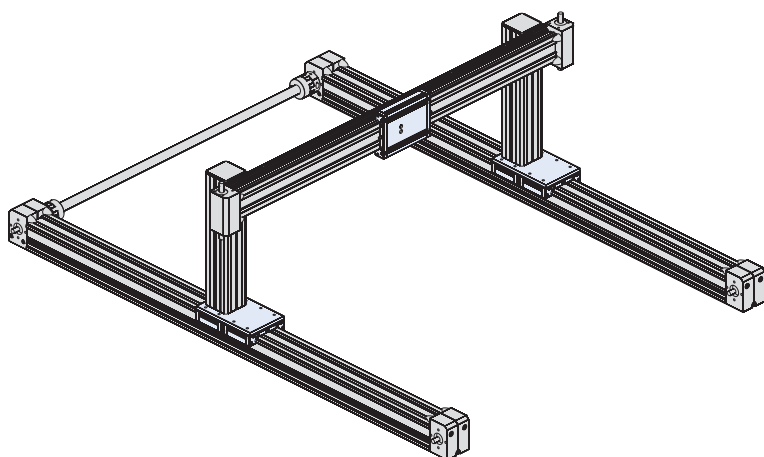

2-axis H-design

- 2 × LEZ 3
- 1 × LEZ 2
- Transmission shaft

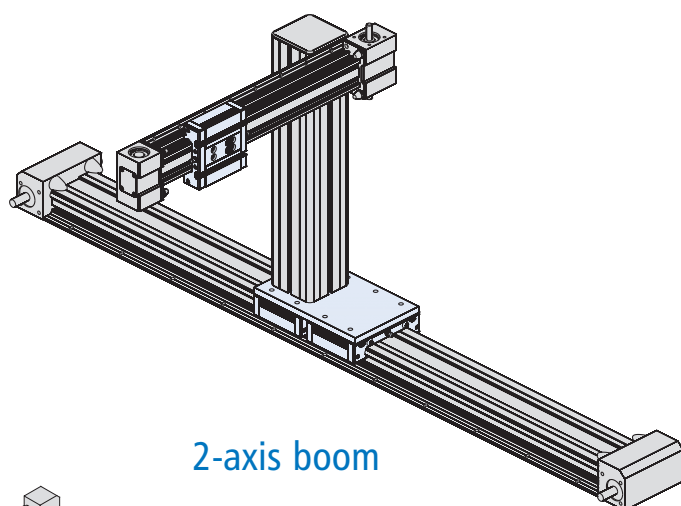

2-axis boom

- 1x LEZ 2
- 1x LEZ 9

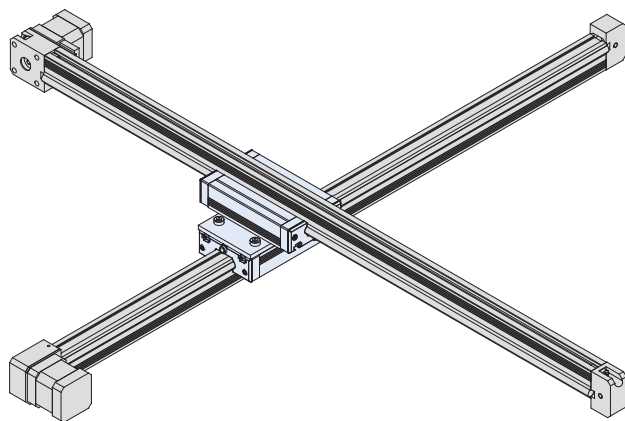

Crossbench LEZ 1

- 2 x LEZ 1

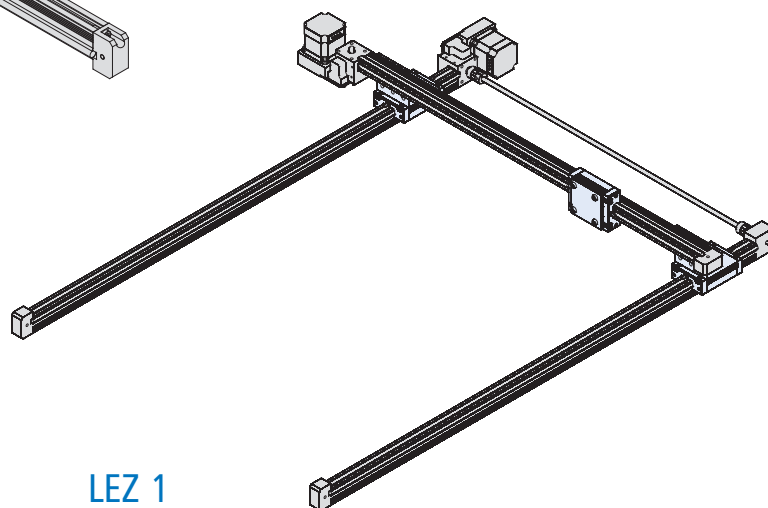

LEZ 1

- 2-axis flatbed configuration

Linear units

with direct drive

iLD

Further information
on request !

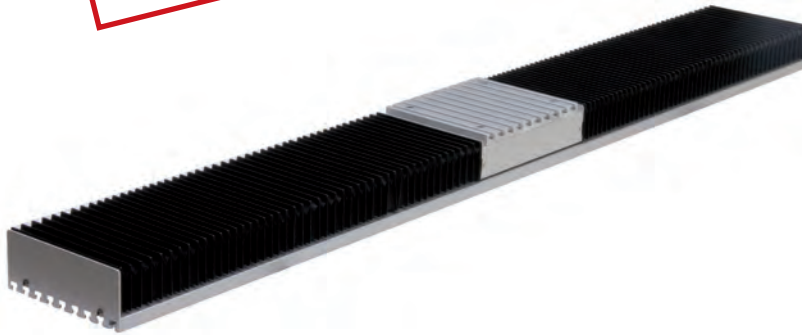

LFS 12-150

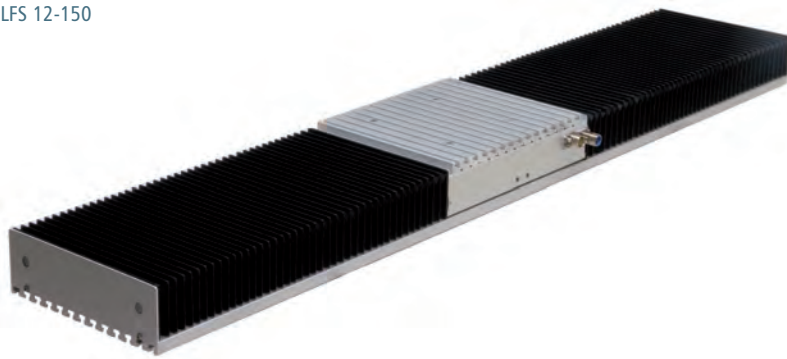

LFS 16-250

Features

- Aluminium linear guide with magnet rail
- internal magnetic tape
- Drive slots with spool package and magnetic length measurement system
- low noise running
- adjustable for no play
- high accelerations and speeds
- no backlash
- No need for mechanical transfer devices
- no servicing and greasing tasks
- with 2 limit or reference switches
- Repeatability $\pm 0.01\text{mm}$
- Standard lengths to 3m (in 100 mm raster)

Options:

- Drive controller
- Folding cover
- Parking brake
- Various winding packages
- Segmentable guide

General

Where the earlier conventional linear units with spindle drives were reaching their development limits, linear units with linear motors are coming to the fore: They are achieving enormous accelerations, move into positions with pinpoint accuracy and work with virtually no wear because of the absence of mechanical connectors.

Linear motors are being used increasingly in machine tools, as well as for positioning systems and handling systems in linear technology. Linear units with steel shaft guides are particularly suited for the machine tools field and positioning systems.

isel iLD series linear units are constructed from rigid aluminium profiles. The guides comprise isel precision steel shafts and isel aluminium shaft slots, proven in use for more than 20 years. The magnetic isel length measurement system is also incorporated.

In this field, Isel linear motor units have the advantage of higher accelerations (up to 30 m/s^2) and processing speeds of up to 4 m/s. Linear motors with iron core produce very high permanent forces, which reach more than 1000 N.

A matching integrated brake is also available as an option. Matching folding bellows covers are also available to protect from dirt. The "made by isel" concept means that an optimum price/performance-ratio is offered, which in its turn means very short amortisation periods for customers.

Linear units

with direct drive

iLD

Dimensioned drawings

LFS 12-150

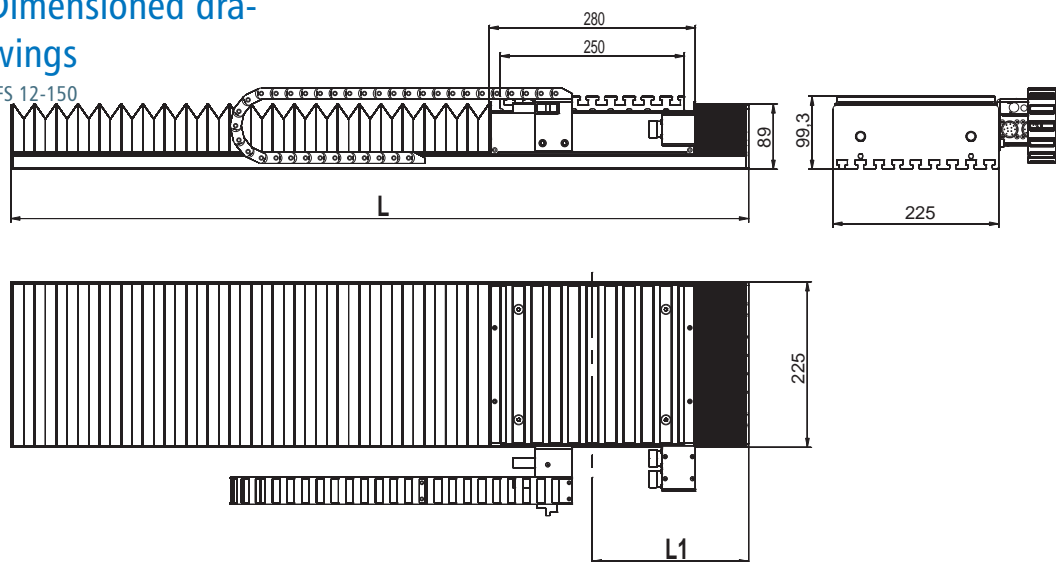

LFS 16-250

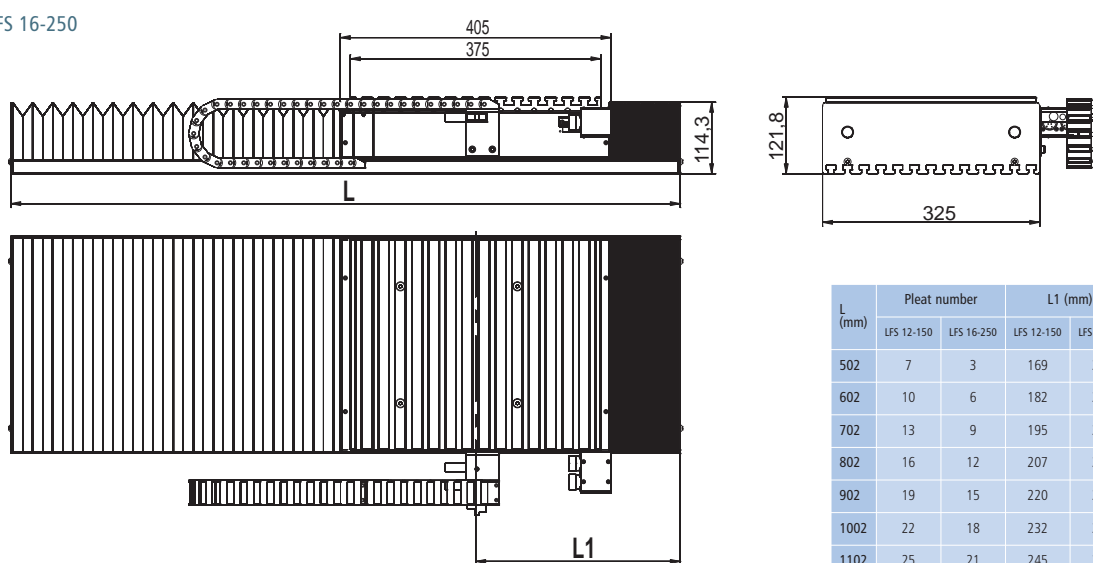

L (mm)	Pleat number		L1 (mm)		Travel (mm)	
	LFS 12-150	LFS 16-250	LFS 12-150	LFS 16-250	LFS 12-150	LFS 16-250
502	7	3	169	215	163	72
602	10	6	182	228	238	147
702	13	9	195	240	313	221
802	16	12	207	253	388	296
902	19	15	220	266	462	371
1002	22	18	232	278	537	446
1102	25	21	245	291	612	521
1202	27	24	253	303	695	595
1302	30	27	266	316	770	670
1402	33	30	279	329	845	745
1502	36	33	291	341	920	820
1602	39	35	304	350	994	903
1702	42	38	316	362	1069	978
1802	45	41	329	375	1144	1053
1902	48	44	342	387	1219	1127
2002	51	47	354	400	1294	1202
2102	54	50	367	413	1368	1277
2202	57	53	379	425	1443	1352
2302	60	56	392	438	1518	1427
2402	63	59	405	450	1593	1501
2502	65	62	413	463	1676	1576
2602	68	65	426	476	1751	1651
2702	71	68	438	488	1826	1726
2802	74	71	451	501	1900	1801
2902	77	74	463	513	1975	1875
3002	80	76	476	522	2050	1959

Rotation units

Overview

RDH-M Indexing table / Rotary unit

C 104



RDH-S Indexing table / Rotary unit

C 106



RDH-XS Indexing table / Rotary unit

C 108



DSH-S Rotary / swivel unit

C 110



RF 1 Indexing table

C 112



Rotation units

Overview

iZD 54 Rotary unit

C 114



MD 1 Miniature rotary unit

C 116



ZD 30 Rotary unit

C 118

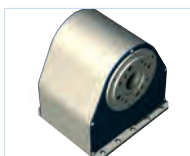

ZR 20 Indexing table

C 120



ZDS 2030

C 121



Pin assignments

C 122

Transported loads

C 123

Machining forces

Feed

CAD data on our website www.isel.com

Indexing table / Rotary unit

RDH-M



RDH-M as indexing table
(solid shaft design)

RDH-M as rotary unit
(hollow shaft design)



Features

- With precision transmission
 - High load capacity, rigid drive bearing
 - Absence of play and high torsional rigidity
- Reduction 1:51 or 1:101
- Stepper or servomotor
- Protection class IP 65
- Stainless design
- Transfer accuracy < 1 minute of arc
- Repeatability < ± 6 seconds of arc
- Available in solid or hollow shaft design
- No maintenance

For pin assignment see page C122
For transport loads see page C123

Ordering key

2 6 6 2 X X 0 X 0 0

Flanged shaft

0 = solid shaft
1 = hollow shaft

Transmission reduction

0 = 101
1 = 51

Motors

0 = Stepper motor MS 200 HAT with encoder (400 imp., 3-channel, RS422)
3 = brushless EC servomotor EC 60S
4 = brushed DC servomotor DC 100
5 = Stepper motor without encoder

Accessories



Chuck assembly

3-jaw chuck \varnothing 125
Part no.: **269062 0125**

4-jaw chuck \varnothing 125
Part no.: **269061 0125***

*including flange



Aluminium T-key plate

\varnothing 240 mm/PT 25
Part no.: **269050 0240**

\varnothing 365 mm/PT 25
Part no.: **269050 0365**



Aluminium rotary plate

\varnothing 490 mm, customised
fixing borings available at extra cost

Part no.: **269051 0500**



Tailstock unit RE M

Part no.: **269100 2100**
(1000 mm)
Part no.: **269100 2150**
(1500 mm)
Part no.: **269100 2200**
(2000 mm)

Indexing table / Rotary unit

RDH-M

Technical specification

	Stepper motor MS 200 HT *		EC servomotor EC 60S (brushless)		DC servomotor DC 100 (brushed)	
Reduction ratio	1:51	1:101	1:51	1:101	1:51	1:101
Nominal speed [1/min]	4	2	22	11	22	11
	at 1500 Hz (225 1/min)		at 1100 1/min			
Max. speed [1/min]	24	12	59	30	59	30
	at 8000 Hz		--			
Nominal torque [Nm]	24	46	9	17	7	14
	bei 1500 Hz		--			
Max. torque (short term) [Nm]	--	--	42	80	39	73
Nominal holding torque (static load) [Nm]	55	108	26	51	15	30
Max. Transmission load [Nm]	98	157	98	157	98	157
	Limit for repeatable peak torque					
Dynamic load factor C [N]	21800					
Static load factor C ₀ [N]	35800					

* Values for half-step operation

Dimensioned drawings

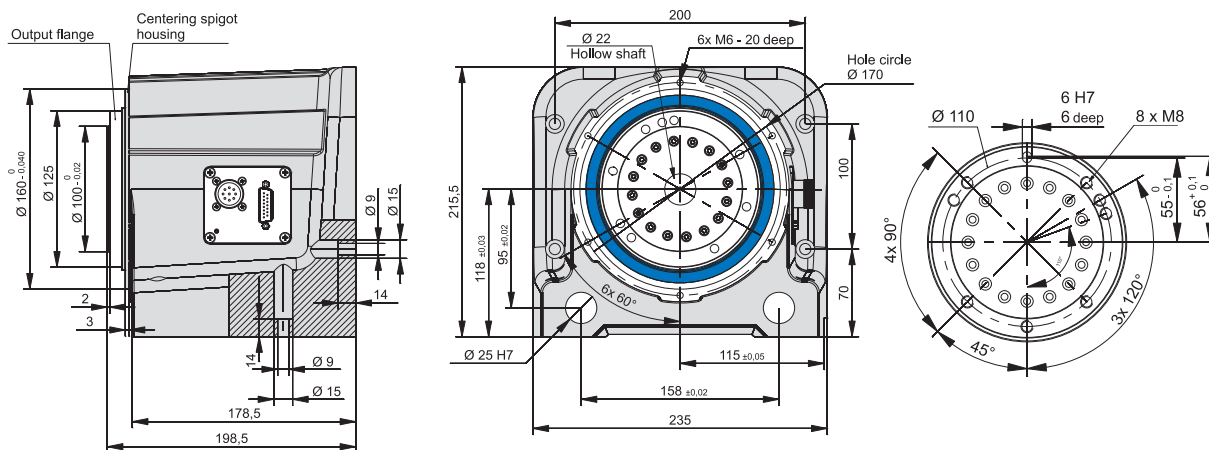

Versions	Part no.	L	A
Tailstock unit RE-M 1000 mm	269100 2100	1110	624,5
Tailstock unit RE-M 1500 mm	269100 2150	1610	1124,5
Tailstock unit RE-M 2000 mm	269100 2200	2110	1624,5

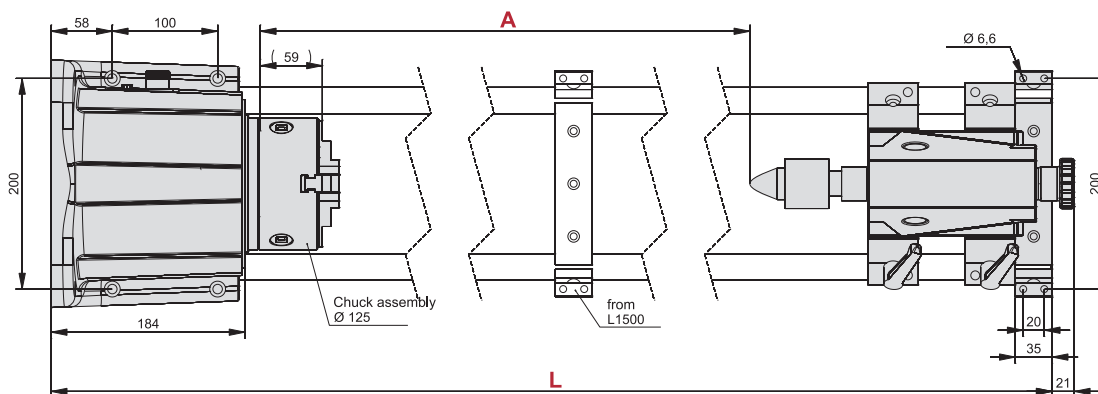

Indexing table / Rotary unit

RDH-S

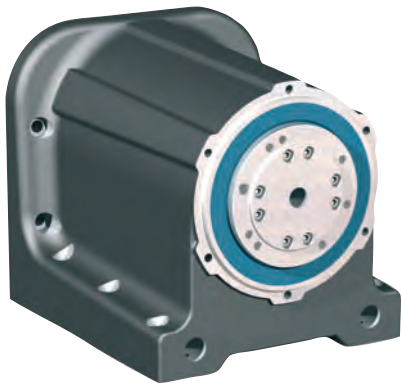

RDH-S as indexing table
(solid shaft design)

RDH-S as rotary unit
(hollow shaft design)



Features

- With precision transmission
 - High load capacity, rigid drive bearing
 - Absence of play and high torsional rigidity
- Reduction 1:51 or 1:101
- Stepper or servomotor
- Protection class IP 65
- Stainless design
- Transfer accuracy < 1.5 minute of arc
- Repeatability < ± 6 seconds of arc
- Available in solid or hollow shaft design
- No maintenance

For pin assignment see page C122
For transport loads, see page C123

Ordering key

2 6 6 1 X X 0 X 0 0

Flanged shaft

0 = solid shaft
1 = hollow shaft

Transmission reduction

0 = 101
1 = 51

Motors

0 = Stepper motor MS 045 HT with encoder (400 imp., 3-channel, RS422)
2 = brushless DC servomotor RE 40
3 = brushless EC servomotor EC 42
5 = Stepper motor without encoder

Accessories



Chuck assembly

3-jaw chuck \varnothing 65

Part no.: **269060 3065***

3-jaw chuck \varnothing 80

Part no.: **269060 2080***

3-jaw chuck \varnothing 100

Part no.: **269060 2100***



Chuck jaws

4-jaw chuck \varnothing 100

Part no.: **269061 2100***

* including flange



Tailstock unit RE S

for RDH-S

Part no.: **269100 1020** (200 mm)

Part no.: **269100 1030** (300 mm)

Part no.: **269100 1040** (400 mm)

Part no.: **269100 1050** (500 mm)

Indexing table / Rotary unit

RDH-S

Technical specification

	Stepper motor MS 045 HT *		EC servomotor EC 42 (brushless)		DC servomotor RE 40 (brushed)	
Reduction ratio	1:51	1:101	1:51	1:101	1:51	1:101
Nominal speed [1/min]	4	2	22	11	22	11
	at 1500 Hz (225 1/min)		at 1100 1/min		at 1100 1/min	
Max. speed [1/min]	24	12	59	30	69	35
	at 8000 Hz		--			
Nominal torque [Nm]	7	11	4.8	9.2	4.6	9
	at 1500 Hz		--			
Max. torque (short term) [Nm]	--	--	7	11	7	11
Nominal holding torque (static load) [Nm]	7	11	7	11	7	11
Max. Transmission load [Nm]	18	28	18	28	18	28
	Limit for repeatable peak torque					
Dynamic load factor C [N]	5800					
Static load factor C ₀ [N]	8600					

* Values at half-step operation

Dimensioned drawings

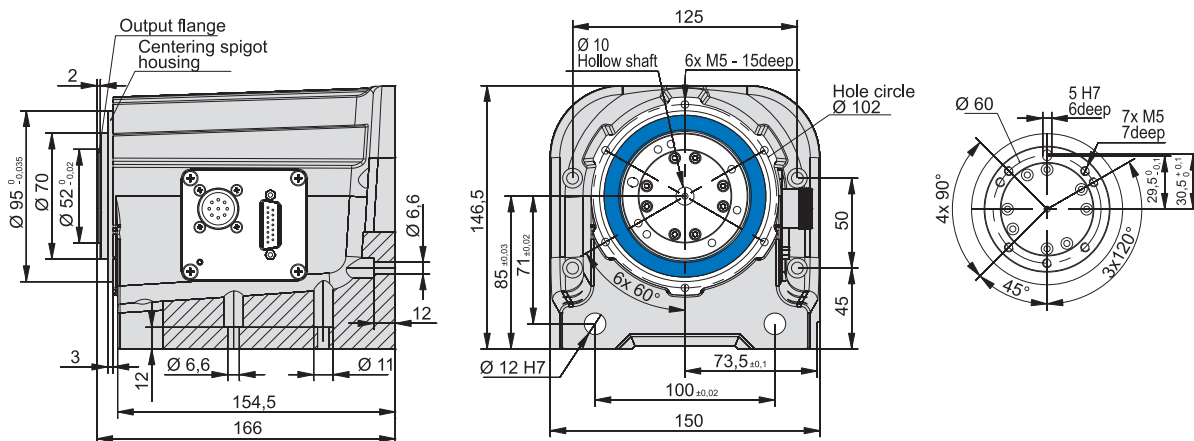

Versions	Part-no.	L	A
Tailstock unit RE-S 200 mm	269100 1020	370	128
Tailstock unit RE-S 300 mm	269100 1030	470	228
Tailstock unit RE-S 400 mm	269100 1040	570	328
Tailstock unit RE-S 500 mm	269100 1050	670	428

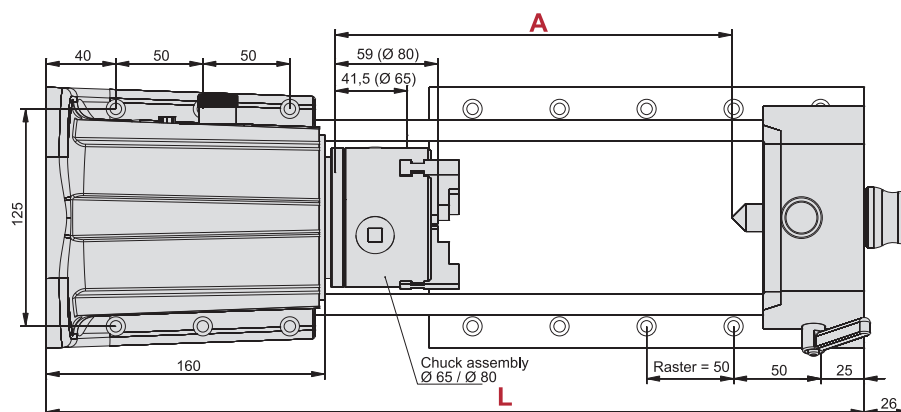

Indexing table / Rotary unit

RDH-XS



RDH-XS as rotary unit

RDH-XS as indexing table



Features

- With precision transmission
 - High load capacity, rigid drive bearing
 - Absence of play and high torsional rigidity
- Reduction 1:50 or 1:100
- Stepper or servomotor
- Protection class IP 65
- Stainless design
- Transfer accuracy <math>< 2</math> minutes of arc
- Repeatability <math>< \pm 1</math> minute of arc
- No maintenance

For pin assignment see page C122
For transport loads, see page C123

Ordering key

2 6 0 0 X 0 X 0 0

Transmission reduction

0 = 100

1 = 50

Motors

0 = Stepper motor MS 045 HT with encoder (400 imp., 3-channel, RS422)

2 = brushed DC servomotor RE 40

3 = brushless EC servomotor EC 42

5 = Stepper motor without encoder

Accessories

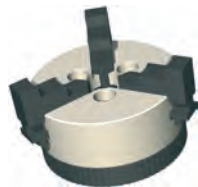

Chuck assembly

3-jaw chuck \varnothing 65Part no.: **269060 4065***

* including flange



Tailstock unit RE XS

for RDH-XS

Part no.: **269100 0020** (200 mm)Part no.: **269100 0030** (300 mm)Part no.: **269100 0040** (400 mm)Part no.: **269100 0050** (500 mm)

Indexing table / Rotary unit

RDH-XS

Technical specification

	Stepper motor MS 045 HT *		EC servomotor EC 42		DC servomotor RE 40	
Reduction ratio	1:50	1:100	1:50	1:100	1:50	1:100
Nominal speed [1/min]	5	2	22	11	22	11
	at 1500 Hz (225 1/min)		at 1100 1/min		at 1100 1/min	
Max. speed [1/min]	24	12	59	30	70	35
	at 8000 Hz (1200 1/min)		--			
Nominal torque [Nm]	5	7	5	7	5	7
	at 1500 Hz (225 1/min)		--			
Max. torque (short term) [Nm]	--	--	5	7	5	7
Nominal holding torque (static load) [Nm]	5	7	5	7	5	7
Max. Transmission load [Nm]	9	14	9	14	9	14
	Limit for repeatable peak torque					
Dynamic load C [N]	392					
Static load C ₀ [N]	392					

* Values for half-step operation

Dimensioned drawings

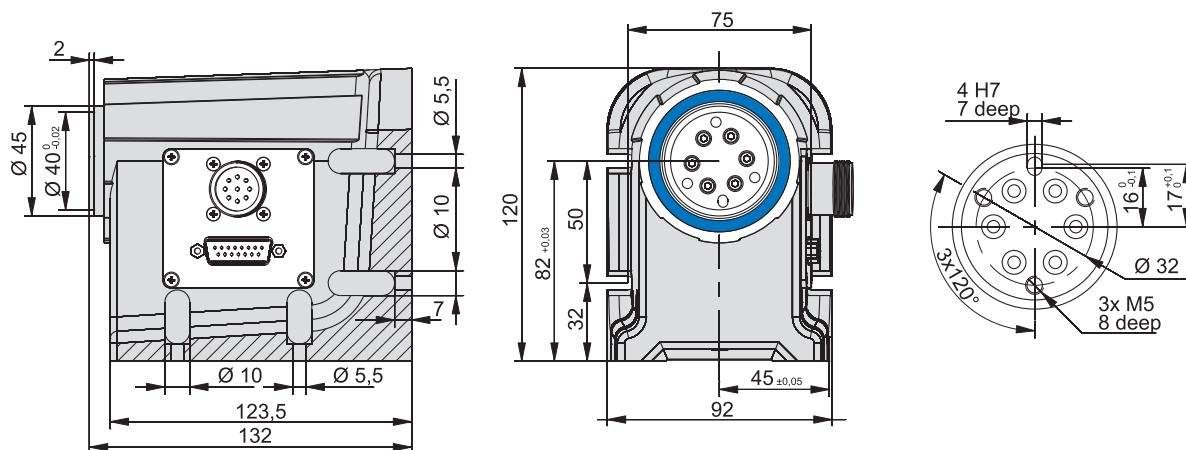

Versions	Part no.	L	A
Tailstock unit RE-XS 200 mm	269100 0020	325	117
Tailstock unit RE-XS 300 mm	269100 0030	425	217
Tailstock unit RE-XS 400 mm	269100 0040	525	317
Tailstock unit RE-XS 500 mm	269100 0050	625	417

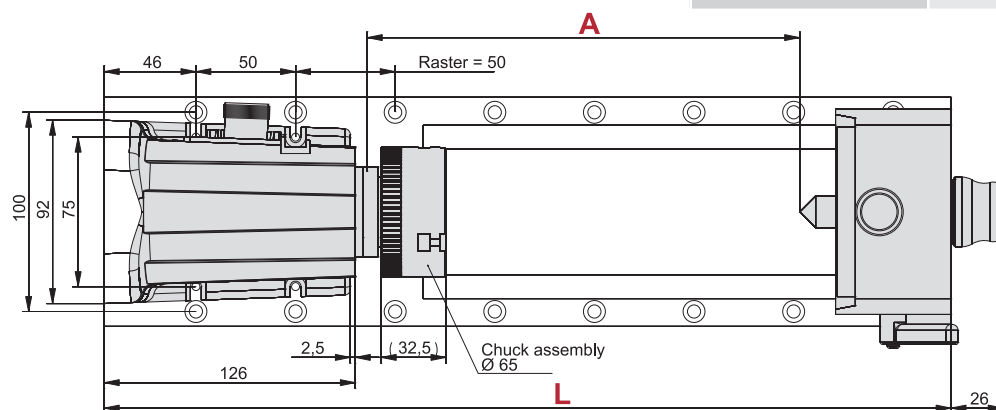

Rotary / swivel unit

DSH-S



Features

- With precision transmission
 - High load capacity, rigid drive bearing
 - Absence of play and high torsional rigidity
- With rotary unit RDH-S
- Reduction 1:51 or 1:101
- Stepper or servomotor
- Protection class IP 65
- Stainless design
- Transfer accuracy < 1.5 minute of arc
- Repeatability < ± 6 seconds of arc
- No maintenance
- Swivel range continuously variable

For pin assignment see page C122
For transport loads, see page C123

Ordering key

2 6 5 4 1 X X 0 0 0

Motors

- 0 = Stepper motor MS 045 HT with encoder (400 imp., 3-channel, RS422)
- 2 = brushed DC servomotor RE 40
- 3 = brushless EC servomotor EC 42
- 5 = Stepper motor without encoder

Transmission reduction

- 0 = 1 : 101
- 1 = 1 : 51

Accessories



Chuck assembly
3-jaw chuck \varnothing 65
Part no.: **269060 3065***

3-jaw chuck \varnothing 80
Part no.: **269060 2080***

3-jaw chuck \varnothing 100
Part no.: **269060 2100***



Chuck assembly
4-jaw chuck \varnothing 100
Part no.: **269061 2100***

* including flange



Circular plate
 \varnothing 150
Part no.: **269 050 0150**

Rotary / swivel unit

DSH-S

Technical specification

	Stepper motor MS 045 HT *		EC servomotor EC 42		DC servomotor RE 40	
	1:51	1:101	1:51	1:101	1:51	1:101
Reduction ratio	1:51	1:101	1:51	1:101	1:51	1:101
Nominal speed [1/min]	4	2	22	11	22	11
	at 1500 Hz (225 1/min)		at 1100 1/min		at 1100 1/min	
Max. speed [1/min]	24	12	59	30	69	35
	at 8000 Hz		--		--	
Nominal torque [Nm]	7	11	4.8	9.2	4.6	9
	at 1500 Hz		--		--	
Max. torque (short term) [Nm]	--	--	7	11	7	11
Nominal holding torque (static load) [Nm]	7	11	7	11	7	11
Max. transmission load [Nm]	18	28	18	28	18	28
	Limit for repeatable peak torque					
Dynamic load factor C [N]	5800					
Static load factor C ₀ [N]	8600					

* Values for half-step operation

Dimensioned drawings

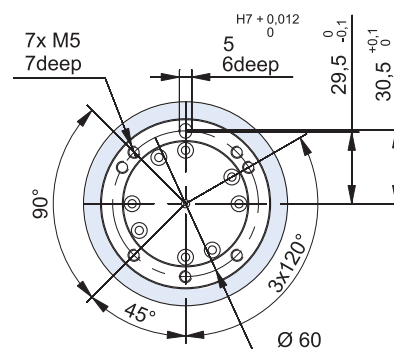
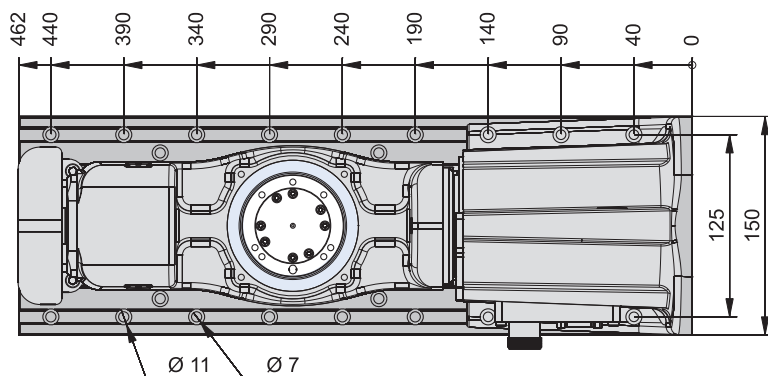
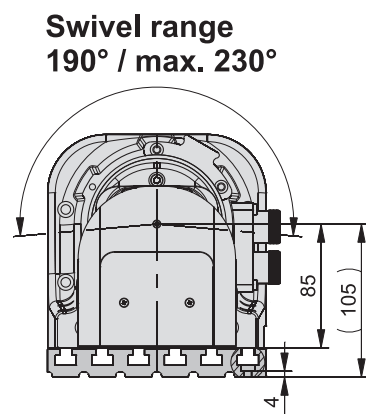
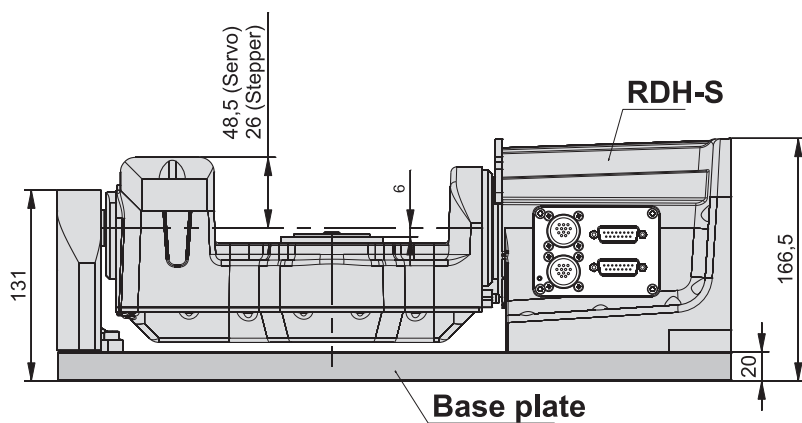

Indexing table

RF 1



Features

- Low play toothed belt drive with stepper or DC servo motor
- Reduction 1: 24 (standard)
- Weight: 14.6 kg

For pin assignment see page C122
For transport loads, see page C123

Options:

- Reduction installation set
1 : 52 or 1 : 100
- Electromagnetic brake [60 Nm]
- Step motor drive with encoder
- CNC controller

Ordering key

2 6 0 2 4 X X X 0 0

Motors

- 1 = Stepper motor MS 200 HT without encoder
- 4 = brushed DC servomotor DC 100
- 5 = brushless EC servomotor EC 60S

Brake

- 0 = without brake
- 1 = magnetic brake

Plug

- 1 = servomotor: M23 + SubD15
- 2 = Stepper motor: SubD9

Accessories

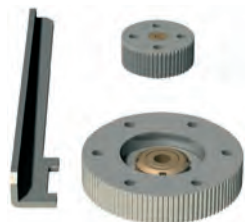

Installation set

for reduction 1:52

Part no.: **269077 0001**

f for reduction 1:100

Part no.: **269077 0002**



Aluminium T-key plate

Ø 240 mm/PT 25

Part no.: **269050 0240**

Ø 365 mm/PT 25

Part no.: **269050 0365**



Aluminium rotary plate

Ø 490 mm, customised fixing borings available at extra cost

Part no.: **269051 0500**



Chuck assembly

3-jaw chuck Ø 125

Part no.: **269062 0125**

4-jaw chuck Ø 125

Part no.: **269061 0125**

Indexing table

RF 1

Technical specification

	Stepper motor MS 200 HT *			servomotor DC 100 / EC 60S		
Reduction ratio	1:24	1:52	1:100	1:24	1:52	1:100
speed [1/min]	0-50	0-23	0-12	0-125	0-58	0-30
Operation torque (0 - 500 Hz) [Nm]	20	42	75	--		
Operation torque (500 - 1000 Hz) [Nm]	18	38	75	--		
Nominal torque [Nm]	--			6 / 10	13 / 22	25 / 42
Nominal holding torque (static load) [Nm]	37	75	75	7 / 12	16 / 26	30 / 50
Min. Step (positional accuracy) [arcmin]	2.5	2	2	2	2	2

* Values for half-step operation

Dimensioned drawings

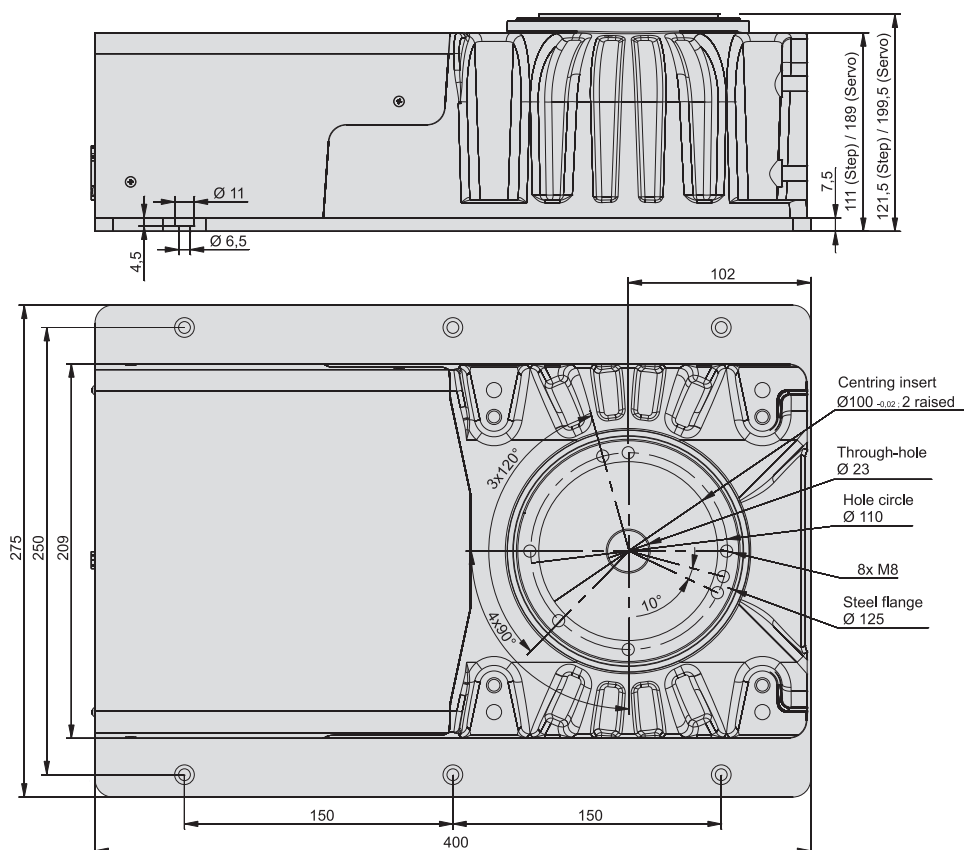

Rotary unit

iZD 54

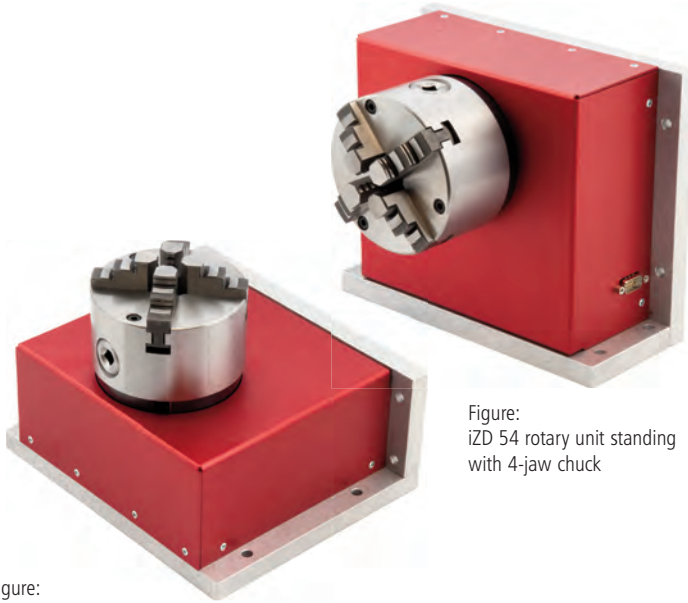

Figure:
iZD 54 rotary unit standing
with 4-jaw chuck

Figure:
iZD 54 rotary unit lying
with 4-jaw chuck

Features

- low play toothed belt drive with stepper motor
- horizontal and vertical
- Reduction 1:54
- good price/performance ratio
- high torque
- Dimensions (L×W×H):
220 × 185 × 95 mm
- Weight approx. 6.5 kg

For pin assignment see page C122
For transport loads, see page C123

Technical specification

Rotary unit iZD 54

Reduction ratio		1:54
Speed	[1/min]	0-22
Operating torque	[Nm]	30
Nominal holding torque (static load)	[Nm]	48
Min. step	[arcmin]	2

based max. 8 kHz, half-step operation

Ordering data

Basic iZD 54 rotary unit
Part no.: **260400 0000**

Accessories



Chuck assembly

3-jaw chuck Ø 100

Part no.: **269060 0100**



4-jaw chuck Ø 100

Part no.: **269061 0100**



Aluminium T-key plate Ø 250 mm, PT 24

Part no.: **269050 0250**

Rotary unit

iZD 54

Dimensioned drawing

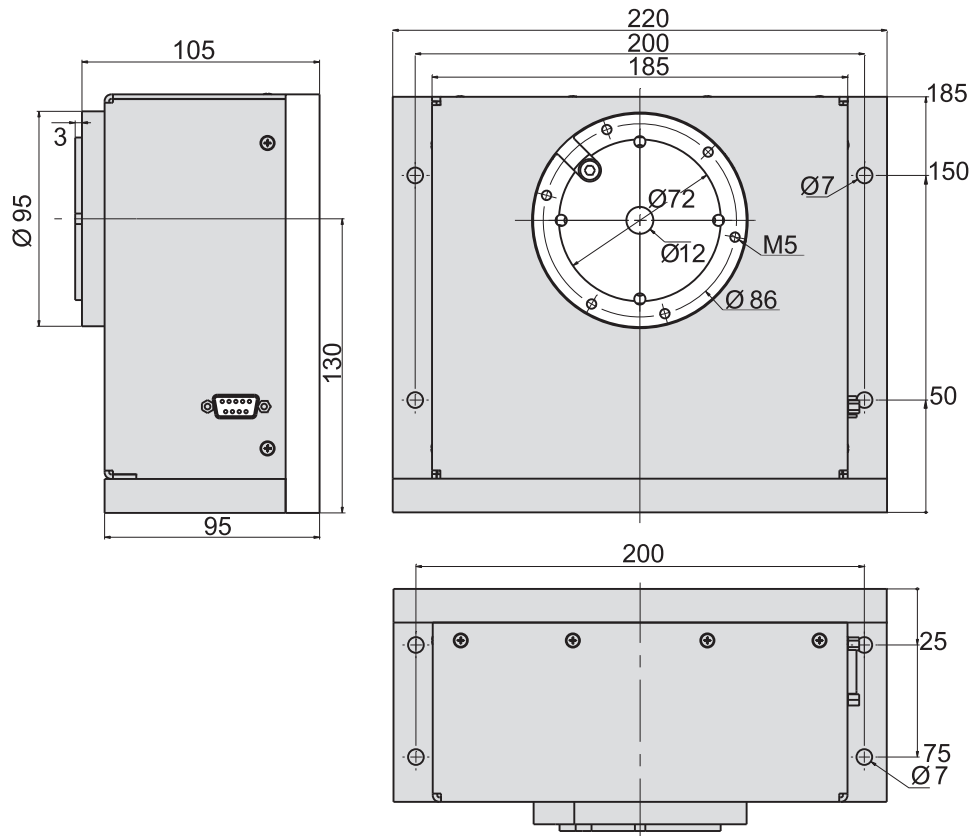

Mini rotary unit

MD 1

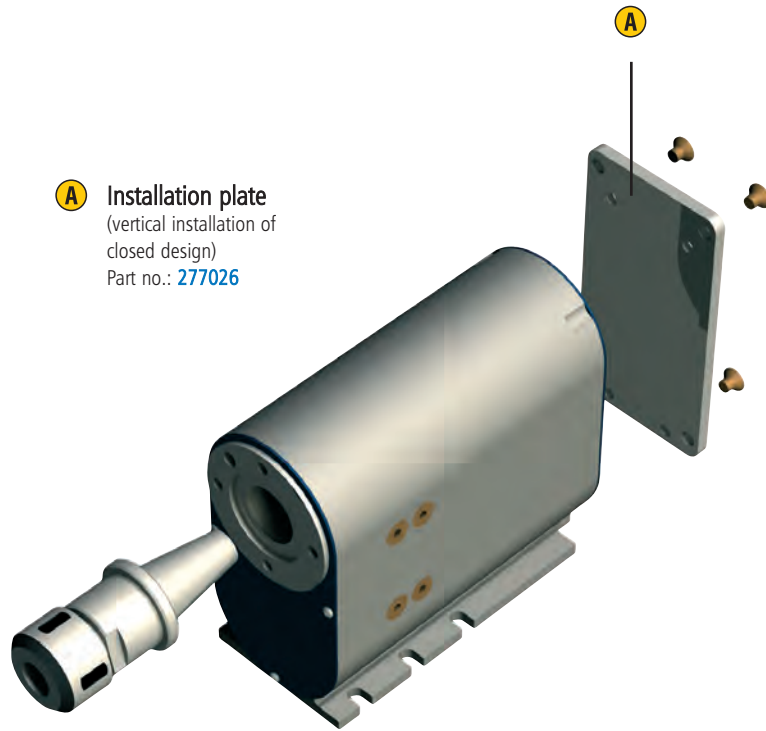

A Installation plate
(vertical installation of
closed design)
Part no.: **277026**

Features

- low play toothed belt drive with stepper or DC servo motor
- Reduction 1: 20
- Shaft with \varnothing 9 mm boring
- Housing flange with inner cone SK 20
- Weight:
according to design, from 1.35 kg

For pin assignment see page C122
For transport loads, see page C123

Optionen:

- additional installation plate
(vertical installation possible)
- CNC controller

Ordering key

261010 0X10

Motors

- 0** = Stepper motor MS 045 HT
- 2** = brushed DC servomotor RE 40
- 3** = brushless EC servomotor EC 42

Accessories

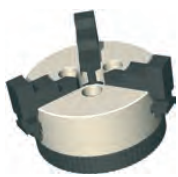

Chuck assembly

3-jaw chuck \varnothing 65
Part no.: **269060 2065***

* including flange



Collet holder

Collet holder SK 20
for tools \varnothing 3 - 10 mm, with
installation ring
Part no.: **239172 0001**

Collets are on page E 29.

Mini rotary unit

MD 1

Technical specification

	Stepper motor MS 045 HT *	DC servomotor RE 40	EC servomotor EC 42
Reduction ratio	1:20	1:20	1:20
Speed [1/min]	0 - 60	0 - 175	0 - 150
Operating torque (0 - 1600 Hz) [Nm]	8	--	--
Nominal torque [Nm]	--	3	3.2
Nominal holding torque (static load) [Nm]	14	3.9	4
Min. step (positional accuracy) [arcmin]	3.5	2	2

* Values for half-step operation

Dimensioned drawings

	Length L for step	Length L for DC servo
closed design	129 mm	180 mm
closed with installation plate	133 mm	184 mm

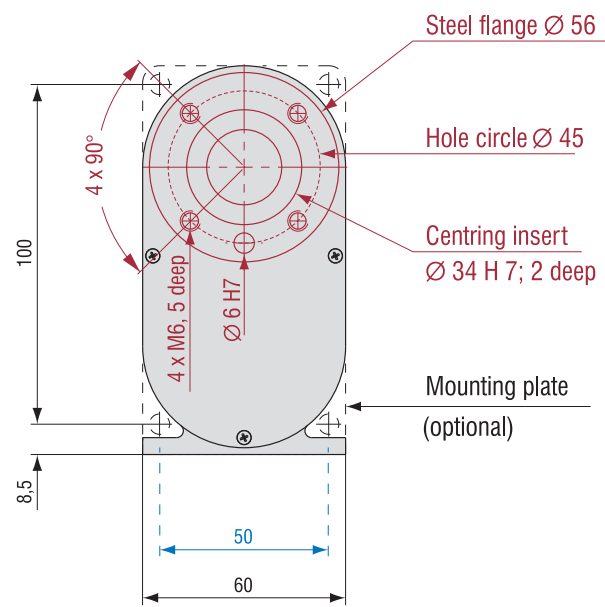
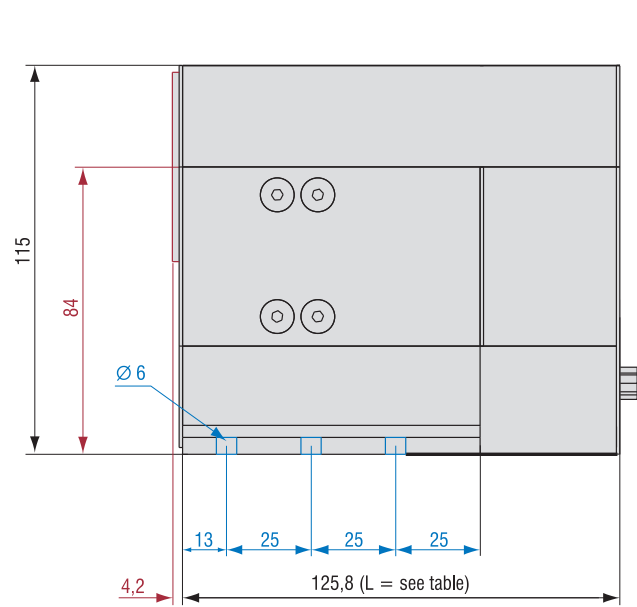
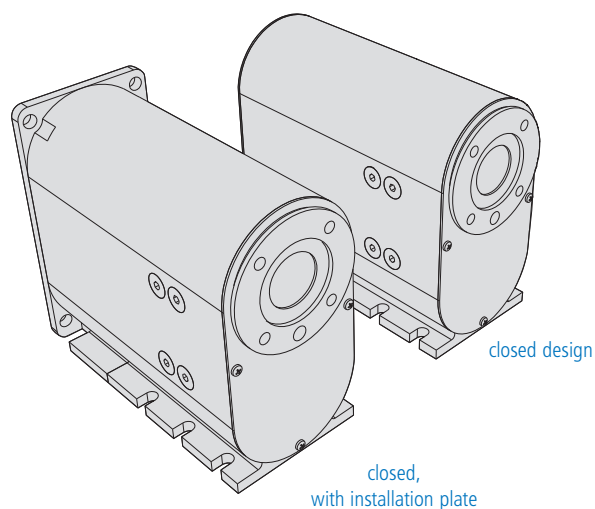

Rotary unit

ZD 30

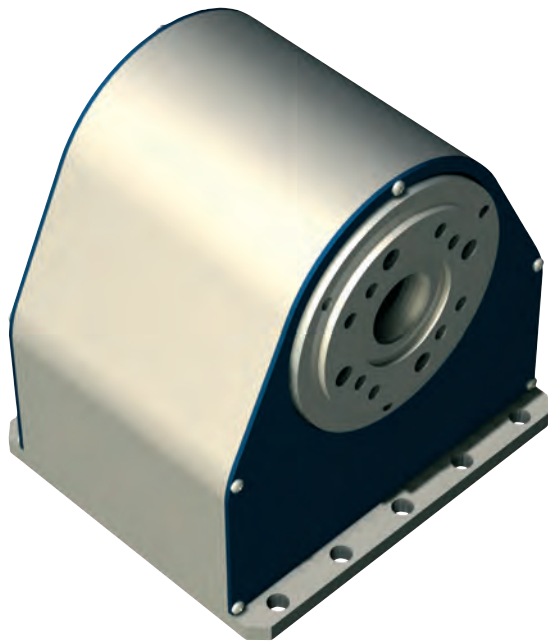

Features

- Low play toothed belt drive with Stepper motor
- Reduction 1 : 30
- Shaft with \varnothing 15 mm boring
- Housing flange with inner cone SK 20
- Weight: 2,9 kg

For pin assignment see page C122
For transport loads, see page C123

Options:

- CNC controller via Sub D

Ordering information

ZD 30 rotary unit
Art.-Nr.: **261100 0000**

Technical specification

		Stepper motor MS 045 HT *
Reduction ratio		1:30
Speed	[1/min]	0 - 40
Operating torque (0 - 1600 Hz)	[Nm]	12
Nominal holding torque (static load)	[Nm]	20
Min. step (positional accuracy)	[arcmin]	2.5

* Values for half-step operation

Accessories

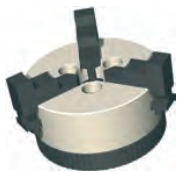

Chuck assembly

3-jaw chuck \varnothing 65
Part no.: **269060 2065***



Chuck assembly

3-jaw chuck \varnothing 80
Part no.: **269060 3080***



Collet holder

Collet holder SK 20
for tools \varnothing 3 - 13 mm, with
installation ring
Part no.: **239172 0001**

Collets are on page E 29.



Tailstock unit RE-ZD30

200 mm Part no.: **269 100 1060** L 331
300 mm Part no.: **269 100 1070** L 431
400 mm Part no.: **269 100 1080** L 531
500 mm Part no.: **269 100 1090** L 631

* including flange

Indexing table

ZR 20

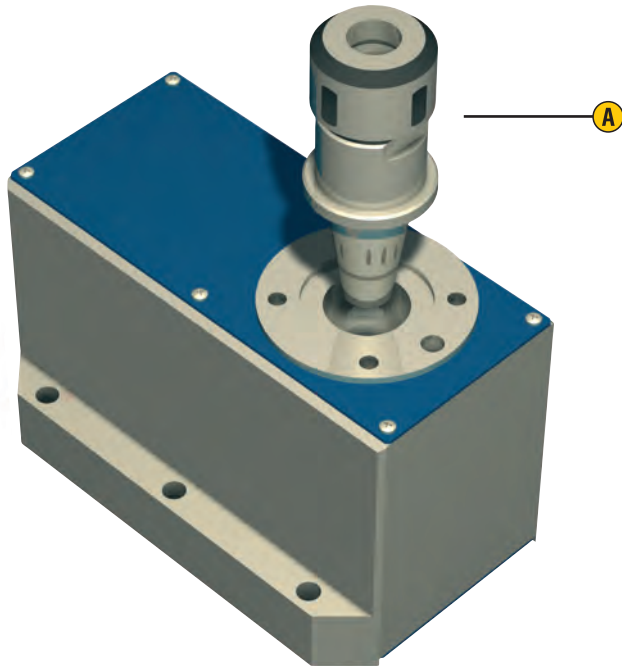

Features

- Low play toothed belt drive with stepper motor
- Reduction 1 : 20
- Shaft with \varnothing 15 mm boring
- Housing flange with inner cone SK 20•
Weight: 2,1 kg

For pin assignment see page C122
For transport loads, see page C123

Options:

- CNC controller via Sub D

- A** Collet holder SK 20
(Accessories)

Ordering data

Indexing table ZR 20
Part no.: **260300 0000**

Technical specifications

		Stepper motor MS 045 HT *
Reduction ratio		1:20
Speed	[1/min]	0 - 60
Operating torque (0 - 1600 Hz)	[Nm]	8
Nominal holding torque (static load)	[Nm]	14
Min. step (positional accuracy)	[arcmin]	3.5

* Values for half-step operation

Accessories

see rotary / swivel unit

Dimensioned drawing

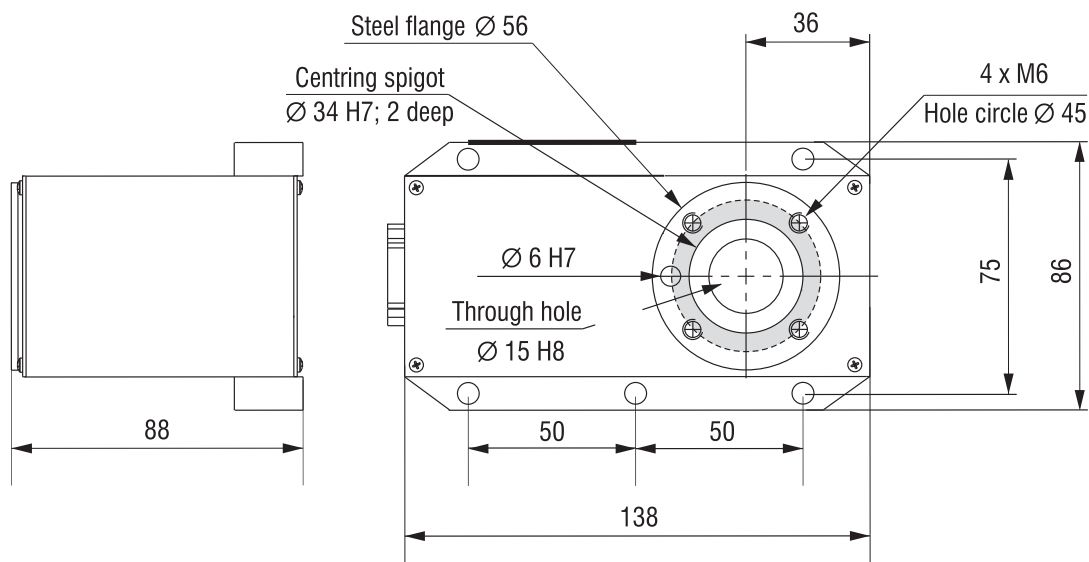

Rotary / swivel unit

ZDS 2030

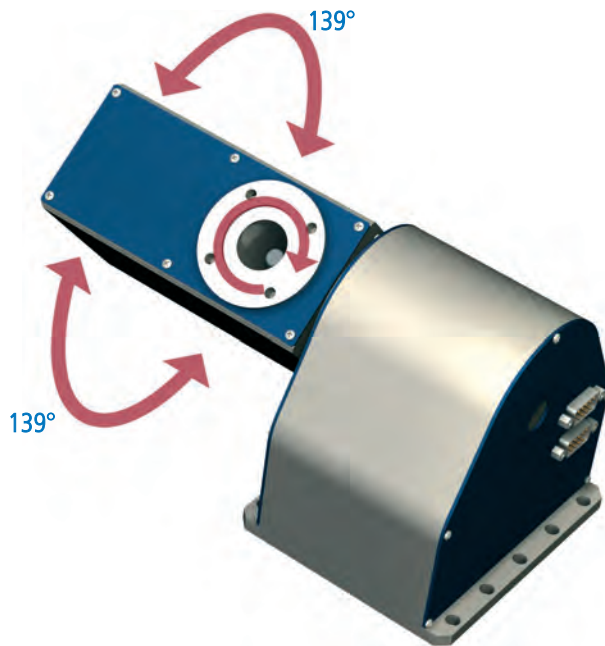

General

The **rotary tilting unit ZDS 2030** can be used as a 4th/5th axis in CNC machines for fine workshops or in the handling area.

It is a combination of ZD 30 and the modified version of ZR 20.

ZDS 2030 enables 5-side machining or free-form surface machining on a conventional 3-axis system of easily machinable materials (e.g. plastic).

The tilting angle is 139° in both directions.

Ordering data

Rotary / swivel unit ZDS 2030
Part no.: **265000 0000**

Accessories

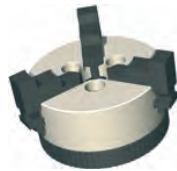

Chuck assembly

3-jaw chuck Ø 65

Part no.: **269060 2065***

* including flange



Collet holder

SK 20 collet holder for tools Ø 3 - 13 mm, with installation ring

Part no.: **239172 0001**

Collets are on page E 29.

Dimensioned drawing

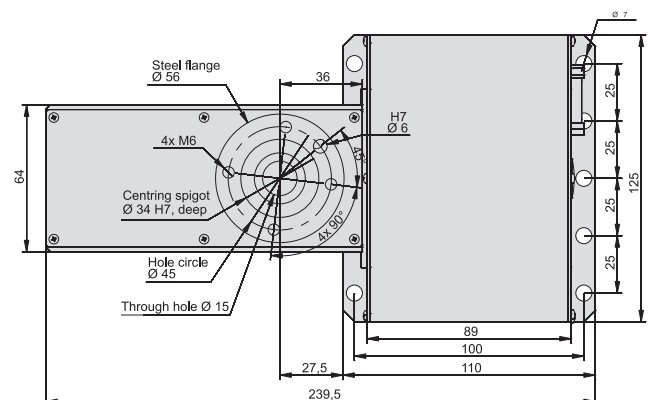
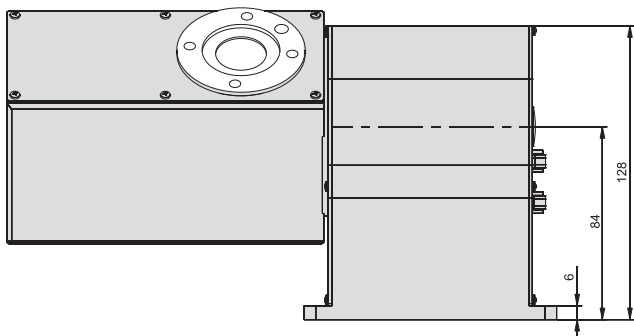

Motor pin assignments

Pin assignment for 12-pin stepper motors

(for RDH, DSH-S)

Motor connection

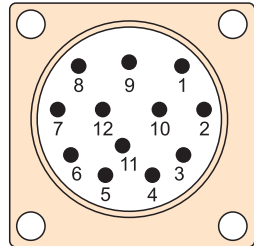

View of pin insert at the insertion side

M23 12-pin Pin	
1	Motor phase 1A
2	Motor phase 1B
3	Motor phase 2A
4	Motor phase 2B
5	+24V switch
6	+24V brake
7	GND switch
8	GND brake
9	Limit switch 1
10	Limit switch 2
11	---
12	---
Housing – cable shield	

Pin assignment for 9-pin stepper motors

(for RF1, iZD 54, MD 1, ZD 30, ZR 20, ZDS 2030)

Motor connection

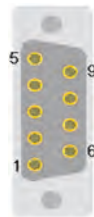

View of pin insert at the insertion side

Sub-D 9-pin Pin	
1	Motor phase 1A
2	Motor phase 1B
3	Motor phase 2A
4	Motor phase 2B
5	+24V switch
6	+24V brake
7	Limit switch 2
8	GND brake
9	Limit switch 1
Housing – cable shield	

Pin assignment for stepper motors with encoder

(for RDH)

Motor connection

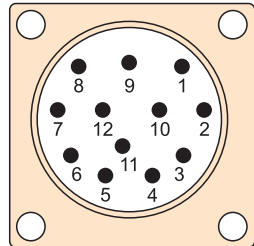

View of pin insert at the insertion side

M23 12-pin Pin	
1	Motor phase 1A
2	Motor phase 1B
3	Motor phase 2A
4	Motor phase 2B
5	+24V switch
6	+24V brake
7	GND switch
8	GND brake
9	Limit switch 1
10	Limit switch 2
11	---
12	---
Housing – cable shield	

Encoder connection



View of pin insert at the insertion side

Sub-D 9-pin Pin	
1	+5V encoder
2	Encoder track A
3	Encoder track B
4	Encoder track Z
5	---
6	GND encoder
7	Encoder track /A
8	Encoder track /B
9	Encoder track /Z
Housing – cable shield	

Pin assignment for brushed DC servo motors (BDC)

Motor connection

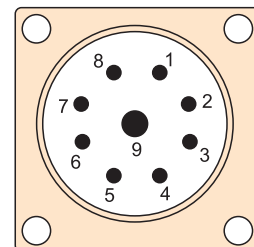

View of pin insert at the insertion side

M23 9-pin (8+1) Pin	
1	Motor phase 1 (U+)
2	Motor phase 1 (U-)
3	Motor phase 1 (U+)*
4	Motor phase 1 (U-)*
5	+24V brake
6	GND brake
7	---
8	---
9	Earthing lead
Housing – cable shield	

* Motor phases are connected partially over 2 wires.

Encoder connection

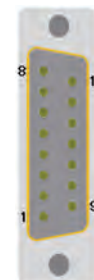

View of pin insert at the insertion side

Sub-D 15-pin Pin	
1	---
2	+5V encoder
3	Encoder track /Z
4	Encoder track /B
5	Encoder track /A
6	+24V switch
7	Limit switch 1
8	GND switch
9	---
10	GND encoder
11	Encoder track Z
12	Encoder track B
13	Encoder track A
14	Reference switch
15	Limit switch 2
Housing – cable shield	

Pin assignment for brushless EC servo motors (BLDC)

Motor connection

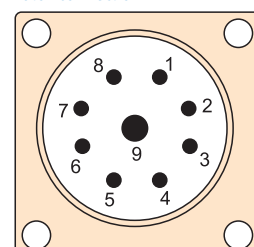

View of pin insert at the insertion side

M23 9-pin (8+1) Pin	
1	Motor phase U
2	Motor phase V
3	Motor phase W
4	---
5	+24V brake
6	GND brake
7	---
8	---
9	Earthing lead
Housing – cable shield	

Encoder connection



View of pin insert at the insertion side

Sub-D 15-pin Pin	
1	Hall signal A
2	+5V encoder / Hall
3	Encoder track /Z
4	Encoder track /B
5	Encoder track /A
6	+24V switch
7	Limit switch 1
8	GND switch
9	Hall signal B
10	GND encoder
11	Encoder track Z
12	Encoder track B
13	Encoder track A
14	Hall signal C
15	Limit switch 2
Housing – cable shield	

Rotary- / swivel- / Rotation units

Transport loads, machining forces, feed

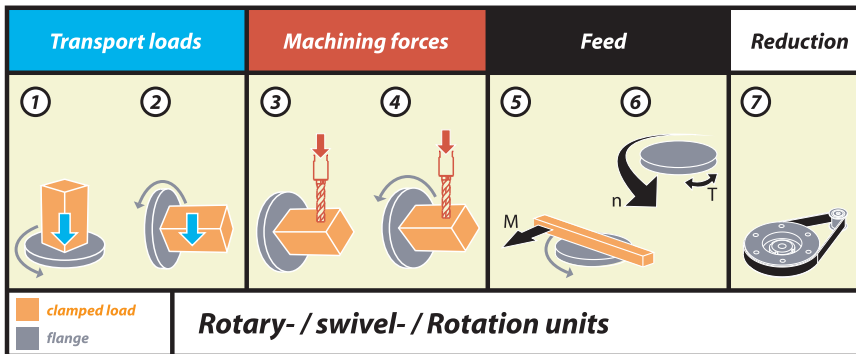

Rotary or Swivel units	1*	2*	3	4	5	6	7
RDH-M (step)	100 kg	45 kg	55 Nm	24 Nm	24 Nm	4 1/min.	1:51
RDH-M (step)	160 kg	70 kg	108 Nm	45 Nm	45 Nm	2 1/min.	1:101
RDH-M (brushless EC-servo)	110 kg	50 kg	26 Nm	9 Nm	9 Nm	22 1/min.	1:51
RDH-M (brushless EC-servo)	180 kg	80 kg	51 Nm	17 Nm	17 Nm	11 1/min.	1:101
RDH-S (Step)	30 kg	15 kg	7 Nm	7 Nm	7 Nm	4 1/min.	1:51
RDH-S (Step)	48 kg	24 kg	11 Nm	11 Nm	11 Nm	2 1/min.	1:101
RDH-S (brushless EC-servo)	30 kg	15 kg	7 Nm	4.6 Nm	4.6 Nm	22 1/min.	1:51
RDH-S (brushless EC-servo)	48 kg	24 kg	11 Nm	4.6 Nm	9.2 Nm	11 1/min.	1:101
RDH-S (DC-Servo)	25 kg	13 kg	7 Nm	4.6 Nm	4.6 Nm	22 1/min.	1:51
RDH-S (DC-Servo)	40 kg	20 kg	11 Nm	8.7 Nm	8.7 Nm	11 1/min.	1:101
RDH-XS (Step)	30 kg	10 kg	5 Nm	5 Nm	5 Nm	24 1/min.	1:50
RDH-XS (Step)	30 kg	10 kg	7 Nm	7 Nm	7 Nm	12 1/min.	1:100
RDH-XS (brushless EC-Servo)	30 kg	10 kg	5 Nm	5 Nm	5 Nm	59 1/min.	1:50
RDH-XS (brushless EC-Servo)	30 kg	10 kg	7 Nm	7 Nm	7 Nm	30 1/min.	1:100
RDH-XS (DC-Servo)	30 kg	10 kg	5 Nm	5 Nm	5 Nm	70 1/min.	1:50
RDH-XS (DC-Servo)	30 kg	10 kg	7 Nm	7 Nm	7 Nm	35 1/min.	1:100
RF 1 (Step)	60 kg	30 kg	37 Nm	17.5 Nm	17.5 Nm	50 1/min.	1:24
RF 1 (Step)	100 kg	50 kg	75 Nm	38 Nm	38 Nm	23 1/min.	1:52
RF 1 (Step)	150 kg	75 kg	75 Nm	75 Nm	75 Nm	12 1/min.	1:100
RF 1 (DC-Servo / EC Servo)	70 kg	35 kg	7 / 12 Nm	6 / 10 Nm	6 / 10 Nm	125 U/min.	1:24
RF 1 (DC servo / EC servo)	110 kg	55 kg	16 / 26 Nm	13 / 22 Nm	13 / 22 Nm	58 U/min.	1:52
RF 1 (DC servo / EC servo)	160 kg	80 kg	30 / 50 Nm	25 / 42 Nm	25 / 42 Nm	30 U/min.	1:100
MD 1 (Step)	5 kg	2,5 kg	14 Nm	8 Nm	8 Nm	60 U/min.	1:20
MD 1 (DC servo)	6 kg	3 kg	3,9 Nm	3 Nm	3 Nm	175 U/min.	1:20
MD 1 (brushless EC-servo)	6 kg	3 kg	4 Nm	3,2 Nm	3,2 Nm	150 U/min.	1:20
ZR 20 (step)	10 kg	5 kg	14 Nm	8 Nm	8 Nm	60 U/min.	1:20
ZD 30 (Step)	14 kg	8 kg	20 Nm	12 Nm	12 Nm	40 U/min.	1:30
iZD 54	30 kg	15 kg	48 Nm	30 Nm	30 Nm	22 U/min.	1:54

*) Guideline values, which will vary according to the use.